

# ENERVEX POWERSTACK CHIMNEY SYSTEM

Models EPS, EPS1, EPS2 & EPS4

11 - 16 - 2015

VOLKO SUPPLY  
800-685-8263

3002603 11.15

Installation & Operating Manual

Sizes 4–24" (100–610mm)

(for larger diameters, please refer to PowerStack+)



**ENGINE EXHAUST**  
**BOILER BREECHING/STACK**  
**SPECIAL GAS VENT**  
**FUME VENTING**  
**GREASE DUCT**  
**PIZZA OVEN CHIMNEY**  
**BBQ CHIMNEY/EXHAUST**  
**DISHWASHER EXHAUST**

A MAJOR CAUSE OF CHIMNEY RELATED FIRES IS FAILURE TO MAINTAIN REQUIRED CLEARANCES (AIR SPACES) TO COMBUSTIBLE MATERIALS. IT IS OF UTMOST IMPORTANCE THAT THIS CHIMNEY BE INSTALLED ONLY IN ACCORDANCE WITH THESE INSTRUCTIONS.

**READ AND SAVE THESE INSTRUCTIONS!**



UL File MH49940

Manufactured in partnership with SFL Ltd, UK

ENERVEX Inc.  
1685 Bluegrass Lakes  
Parkway  
Alpharetta, GA 30004  
USA

P: 770.587.3238  
F: 770.587.4731  
T: 800.255.2923  
info@enervex.com  
www.enervex.com

**ENERVEX®**  
VENTING DESIGN SOLUTIONS





**LISTED**

UL File MH49940

This symbol shows that ENERVEX PowerStack venting systems are listed in the US and certified for Canada under Underwriters Laboratories Inc. file no. MH49940.

**IMPORTANT: READ THESE INSTRUCTIONS CAREFULLY PRIOR TO INSTALLATION.**

- **EXAMINE ALL COMPONENTS FOR POSSIBLE SHIPPING DAMAGE PRIOR TO INSTALLATION.**
- **PROPER JOINT ASSEMBLY IS ESSENTIAL FOR A SAFE INSTALLATION. FOLLOW THESE INSTRUCTIONS EXACTLY AS WRITTEN. CHECK SECURENESS OF JOINTS UPON COMPLETION OF ASSEMBLY.**
- **THIS VENTING SYSTEM MUST BE FREE TO EXPAND AND CONTRACT. THIS VENTING SYSTEM MUST BE SUPPORTED IN ACCORDANCE WITH THESE INSTRUCTIONS.**
- **CHECK FOR UNRESTRICTED VENT MOVEMENTS THROUGH WALLS, CEILINGS, AND ROOF PENETRATIONS.**
- **DIFFERENT MANUFACTURERS HAVE DIFFERENT JOINT SYSTEMS AND ADHESIVES. DO NOT MIX PIPE, FITTINGS, OR JOINING METHODS FROM DIFFERENT MANUFACTURERS.**

**WARNING**

**Failure to follow these installation instructions could cause FIRE, CARBON MONOXIDE POISONING, and/or DEATH. If you are unsure of installation requirements, contact ENERVEX.**

The following caution notice is used throughout this manual to bring attention to the presence of potential hazards, or to important information concerning the product.



Caution: Indicates an imminent hazardous situation which, if not avoided, may result in personal injury or property damage.

**How to use this manual**

This installation manual does not contain any system design documentation. System design documentation is available from any authorized ENERVEX representative. Accessories, fans, and variable frequency drives are not covered by this manual. Please refer to these components' individual manuals.

## Content

<b>1. GENERAL INFORMATION</b>	
1.1 Introduction	4
1.2 Features	4
1.3 System Design and Calculations	4
1.4 Underwriters Laboratories Listings	4
1.5 Applications	5
1.6 Engine and Turbine Exhaust	5
1.7 Other Applications	5
1.8 Special Notes about Special Gas Vent Installations	6
1.9 Special Notes about Liner Installations	6
1.10 Terminations	7
1.11 Surroundings / Enclosure	7
1.12 Multi-Engine Exhaust	7
1.13 Clearances	8
1.14 Pipe Weight	8
1.15 Pipe Joint Assembly	9
1.16 Support Methods	9
1.17 Vertical Support	9
1.18 Vertical Guide Spacing	10
1.19 Horizontal Support Spacing	10
1.20 Thermal Expansion	11
1.21 Chimney Guying And Bracing	12
1.22 Seismic Requirements	12
<b>2. CONNECTION AND ADAPTERS</b>	
2.1 Universal Boiler Kit Adapter	13
2.2 Flanged Boiler Kit	13
2.3 Flange Adapter	13
2.4 Appliance Connector	13
2.5 Flange Adapter - ANSI 125/150	14
2.6 Hood Transitions	14
2.7 Transition to Round	14
2.8 Special Adapters	14
<b>3. STRAIGHT LENGTHS</b>	
3.1 Pipe Lengths	15
3.2 Lengths with Test/Nozzle Port	15
3.3 Drain Section	15
<b>4. THERMAL EXPANSION, VARIABLE LENGTHS, BELLOW JOINTS</b>	
4.1 Adjustable Length	16
4.2 Vertical Installation of Bellows and Variable Lengths	17
4.3 Horizontal Installation of Bellows and Variable Lengths	17
4.4 Lined Bellows Lengths	17
<b>5. TEES, ELBOWS, INCREASERS, OFFSETS AND MANIFOLD, DRAINS</b>	
5.1 45° Lateral Tee	18
5.2 90° And 87° Tee	18
5.3 3°, 15°, 30°, 45°, 87°, 90° Elbows	18
5.4 Drain Tee Cap	18
5.5 Tee Cap	19
5.6 Tapered Increaser/Reducer	19
5.7 Step Increaser/Reducer	19
5.8 Stepped Eccentric Increaser/Reducer	19
<b>6. TERMINATIONS</b>	
6.1 General	20
6.2 Stack Cap	20
6.3 Stack Closure Section	20
6.4 Miter Cut Section	20
6.5 Fan Plate Adapter	20
6.6 Fan Adapter Termination	21
<b>7. STRUCTURAL SUPPORT AND GUIDE COMPONENTS</b>	
7.1 Plate Support Assembly	22
7.2 Vertical Support	22
7.3 Wall Support	22
7.4 Horizontal Support	22
7.5 Floor Guide	23
7.6 Wall Guide	23
7.7 Full Angle Ring / Half Angle Ring	23
7.8 Guide Band	23
7.9 Guy Wire Band	24
7.10 Supporting Elbows and Tees	24
7.11 Centering Band	24
<b>8. ROOF PENETRATIONS, THIMBLES AND FLASHING</b>	
8.1 Unvented Insulated Roof Assembly	25
8.2 Insulated Wall Firestop	26
8.3 Wall Firestop	26
8.4 Flashings And Storm Collars	27
<b>9. MISC COMPONENTS</b>	
9.1 Transitions For Inline Power Venters with Flanged Connections	28
9.2 Transitions for Inline Power Venters and Economizers with Bolted Flange Connections	28
9.3 Other Transitions	28
9.4 Excessive Pressure Relief Valve	28
<b>10. SAMPLE SYSTEMS</b>	30
<b>11. GREASE DUCT</b>	
11.1 Applications	31
11.2 Listings	31
11.3 Configurations	31
11.4 Intermixing of System Parts	31
11.5 Surroundings	31
11.6 Clearances	31
11.7 Slopes	32
11.8 Pipe Fitting and Joint Assembly	32
11.9 Maintenance and Safety	32
11.10 Access for Cleaning Grease Ducts	32
11.11 Automatic Cleaning	33
11.12 Fire Suppression	33
11.13 Interconnection with Rectangular Grease Ducts	33
11.14 Grease Tee Access Cap	34
11.15 Inline Access Door	34
11.16 Sample System - GSV Fan	35
<b>12. POSITIVE PRESSURE VENTING SYSTEM LINER AND BREECHING SYSTEM</b>	
12.1 General Installation Guidelines	36
12.2 Construction and Design	37
12.3 Listings	37
12.4 Installation Information	37
12.5 Installing EPS as a Liner in a Masonry Chimney or as a Liner in an Existing Vent	38
12.6 Vent Maintenance	38
<b>13. WARRANTY</b>	
13.1 Standard 1-Year Warranty	39
13.2 Extended 15-Year Warranty	39

## 1. GENERAL INFORMATION

### 1.1 INTRODUCTION

These instructions comprise both general guidelines and special requirements for all parts in the product line. Before specifying a design or beginning an installation please carefully review these instructions.

Contact Local Building or Fire Officials About Restrictions and Installation Inspection in Your Area.

### 1.2 FEATURES

The PowerStack is made for industrial and commercial applications. It is a factory made modular stainless steel venting systems designed for quick assembly. All parts have a male and female end with an integrated special graphite gasket.

The PowerStack is offered in a single wall version and three (3) twin wall insulated versions. All models are available in internal diameters ranging from 4" (100mm) to 48" (610mm). The fully welded liner is manufactured from a special corrosion resistant 316L PCM (Purified Chromium and Molybdenum) stainless steel with a 304 outer case. The double wall versions are insulated with a high density body soluble calcium silicate blanket to ensure rapid draft stabilization and low surface temperature. A pressure capability of up to 60"Wg (14930Pa) and condensate containment is achieved using a graphite gasket which is compressed between two engineered flanges using a U-Band.

All EPS models (all insulation thicknesses) may be intermixed in the same chimney system, provided the proper associated airspace clearances-to-combustibles are maintained. PowerStack is suitable for negative, neutral or positive pressure applications and intended for use in a variety of applications including, but not limited to, the following: Steam and hot water boiler exhaust, water heater exhaust, generator and engine exhaust, turbine exhaust, Fume Venting, Commercial and Industrial Oven Exhaust, Process Exhaust, Chimney Liner, Chutes, Particle Conveying, Dryer Vents and Ventilation Ducts.

The PowerStack is also suitable for and intended for use in other applications including, but not limited to, Type 1 and 2 kitchen hoods, cooking ovens, and gas-fired pizza ovens.

### 1.3 SYSTEM DESIGN AND CALCULATIONS

Complete system sizing and capacity information may be obtained from the "Chimney, Gas Vent, and Fireplace Systems" chapter of the ASHRAE Handbook, from the ENERVEX "Chimney and Exhaust System Design Handbook", or by contacting ENERVEX Technical Support. In spite of any sizing guidelines, when sizing venting systems, it is most important that the appliance manufacturer's installation instructions be followed.

Failure to follow these instructions may result in inadequate vent system performance and/or a violation of the equipment manufacturer's installation requirements. Proper operation of the venting system and appliance is dependent on the use of all parts specified by the manufacturer for use in the particular installation. The performance of the system may be affected if the proper assembly of all required parts is not accomplished.

### 1.4 UNDERWRITERS LABORATORIES LISTINGS

The ENERVEX PowerStack EPS venting systems are Listed by Underwriters Laboratories, Inc. (UL) under UL File MH49940 in the following product categories and diameters indicated:

Model EPS (single wall) - 4" - 48"	
Building Heating Appliance Chimney	UL103
Special Gas Vent	UL1738
Type BH Gas Vent	ULC S636 for Type BH Gas Vent
Chimney Liner	UL1777
Chimney Liner	ULC S635
Grease Duct for Restaurant Cooking Appliances	UL 1978
Grease Duct	ULC S662

Table 1-1a: EPS Listings

Model EPS1, EPS2, EPS4 (double wall) - 4" - 48"	
Building Heating Appliance Chimney	UL103
540°C Industrial Chimney	ULC/ORD C959
1400°F Chimney	UL2561
760°C Industrial Chimney	ULC/ORD C959
Special Gas Vent	UL1738
Type BH Gas Vent	ULC S636-08 for Type BH Gas Vent
Grease Duct for Restaurant Cooking Appliances	UL1978
Grease Duct	ULC S662

Table 1-1b: EPS1, EPS2 and EPS4 Listings

## 1.5 APPLICATIONS

### **UL 103 STANDARD, BUILDING HEATING APPLIANCE CHIMNEY LISTING**

Under this listing, Model EPS, EPS1, EPS2 and EPS4 have been determined suitable for venting flue gases at a temperature not exceeding 1000°F (540°C), under continuous operating conditions, from gas and liquid fuel fired appliances. Intermittent operation (less than one hour) at temperatures not exceeding 1400°F (760°C), and brief (maximum 10 minute) operation at temperatures not exceeding 1700°F (930°C), is also permitted under this application.

### **UL 2561 STANDARD, 1400°F CHIMNEY LISTING / ULC ORD-C959 INDUSTRIAL TYPE 760°C CHIMNEY**

Under this category, Models EPS1, EPS2 and EPS4 have been determined suitable for venting flue gases at a temperature not exceeding 1400°F (760°C), under continuous operating conditions and intermittent service (less than one hour) at temperatures not exceeding 1800°F (760°C). As such, all EPS1, EPS2 and EPS4 models are suitable for use with ovens and furnaces as described in the Chimney Selection Chart of NFPA No. 211, in addition to other Applications.

### **UL 1738 VENTING SYSTEMS FOR GAS-BURNING APPLIANCES, CATEGORIES II, III, AND IV (550°F VENT LISTING) / ULC S-636 STANDARD FOR TYPE BH GAS VENTING SYSTEMS (550°F CHIMNEY LISTING)**

Under this category, Model EPS has been determined suitable for venting of flue gases at a temperature up to 480°F (249°C). EPS1, EPS2 and EPS4 have been determined suitable for venting flue gases at a temperature up to 550°F (288°C), for most types of installations under continuous operating conditions, from gas fired appliances. See Section 1.13 "Clearances" for specific details.

### **POSITIVE PRESSURE LISTING**

**MODELS EPS, EPS1, EPS2 AND EPS4 ARE RATED FOR USE AT A MAXIMUM OF 60 INCH WATER COLUMN INTERNAL PRESSURE AT 1000°F WHEN USED IN A POSITIVE PRESSURE APPLICATION AS A BUILDING HEATING APPLIANCE CHIMNEY. MODEL EPS1, EPS2 AND EPS4 ARE RATED FOR MAXIMUM OF 60 INCH WATER COLUMN INTERNAL PRESSURE AT 1400°F WHEN USED IN A POSITIVE PRESSURE APPLICATION.**

### **UL 1777, STANDARD FOR CHIMNEY LINERS / CAN ULC S635 STANDARD FOR LINING SYSTEMS FOR EXISTING MASONRY OR FACTORY-BUILT CHIMNEY AND VENTS**

Under this category, model EPS has been determined suitable for use in masonry or factory-built chimneys to provide the flue gas venting of liquid, and/or gas fired appliances with flue gases up to 570°F and short term exposure up to 1700°F per UL 1777 and maximum temperatures of 650°C (1200°F) per ULC S635.

### **UL1978, STANDARD FOR GREASE DUCT / ULC S662 STANDARD FOR FACTORY-BUILT GREASE DUCTS**

Under this category, model EPS has been determined suitable for use in installations using exhaust system components for the removal of smoke and grease-laden vapors from commercial, industrial, institutional and similar type applications. They are intended for use a complete systems. They connect to the hood or grease extractor system to the outdoors through an exhauster or blower system. Applications and instructions for this category are covered in Section 11 entitled "Grease Duct".

## 1.6 ENGINE AND TURBINE EXHAUST

When Models EPS, EPS1, EPS2 and EPS4 are used as an engine or turbine exhaust it is intended to be installed in accordance with NFPA 37 "Stationary Combustion Engines and Gas Turbines". This code states, "When such (flue gas) temperatures do not exceed 1000°F (538°C) except for infrequent, brief periods, the engines shall be classified as low heat appliances". For continuous operation over 1000°F and not exceeding 1400°F the exhaust system should be installed as a 1400°F Chimney.

## 1.7 OTHER APPLICATIONS

Insulated models EPS1, EPS2 and EPS4 may be used to meet various needs, such as:

- Reduce outer pipe surface temperature.
  - Reduce building heat gain by retaining energy inside the duct.
  - Increase the efficiency of energy recovery systems by reducing exhaust gas temperature losses.
  - Increase chimney or exhaust system draft loss performance due to reduced exhaust gas temperature drop.
  - Reduce building noise levels caused by high speed or pulsating exhaust induced noise.
- NOTE: Specific tests have not been conducted to measure acoustic performance.
- PowerStack venting systems are intended for use in connecting the heating appliance, engine, or turbine to the outdoors, while operating under positive forced draft, negative induced draft or neutral gravity flow internal pressure conditions.

**1.8 NOTES ABOUT SPECIAL GAS VENT INSTALLATIONS**

When using the EPS models as Special Gas Vent, the following requirements shall be followed:  
 Any horizontally installed portion of the venting system shall have a slope (upwards for Category II, III, or IV appliances or downwards for Category III or IV appliances) not less than 1/4 inch (6.4 mm) every 12 inches (305 mm) to prevent collection of condensate at any location in the assembly; and means shall be provided for draining the condensate.

Due to ice build up and blockage, it is required that the proper sloping be employed when the vent is installed in a horizontal installation. Refer to the appliance manufacturer’s installation instructions for further details regarding the installation of the condensate drain fittings;

A venting system that is mounted at the exterior shall be enclosed below the roof line to limit condensation and protect against mechanical damage.

The installation of condensate drainage lines, neutralisers, or other systems intended for connection to the venting system, with specification of the materials to be used, joining methods, slope, and details concerning connection of the venting system to sanitary waste systems;  
 After installation, the joints and seams shall be checked for gas tightness when using the venting system with a Category III or IV appliance.



**CAUTION**

Not for use with solid-fuel-fired appliances

**1.9 NOTES ABOUT CHIMNEY LINER INSTALLATIONS**

When installing make sure not to use materials other than as specified in the manufacturer’s instructions. The chimney liner shall be sized not less than that specified in the appliance manufacturer’s instructions.

Prior to installation of the liner into a masonry chimney, the chimney shall be thoroughly cleaned (pay special attention to the removal of tar glaze creosote) and checked for cracked, loose, or missing bricks, mortar, or other materials that could



**CAUTION**

Correct liner size is important for proper venting. Correct sizing is also particularly important when venting appliances with low flue gas temperatures in geographical areas that experience sustained low ambient temperature because they may be susceptible to icing / blockage at the outlet and associated equipment and / or personal safety concerns due to improper appliance venting. Unless a specific sizing assessment is conducted and confirms adequate capacity, no portion of the liner should ever be smaller in diameter than the outlet of the appliance it serves.

inhibit correct installation of the chimney lining system. Check the air space clearances between the masonry chimney exterior and combustible materials and verify that the chimney is in accordance with clearance specifications contained in:

1. NFPA 211;
2. Other recognized major building codes; or
3. The manufacturer’s installation instructions.

Per its UL 1777 Listing, model EPS is required to be installed with 1” airspace between the liner and the inside of the masonry chimney that have a minimum 1” airspace between the masonry chimney and surrounding combustibles. Per its ULC-635 Listing, model EPS may be installed within existing chimneys where there is sufficient space to install the liner and with existing clearances between the chimney and surrounding combustibles.

BEFORE BEGINNING ANY INSTALLATION OF MODEL EPS CHIMNEY LINER SYSTEM, CONSULT THE LOCAL CODE INSPECTION AUTHORITY (GAS INSPECTION AUTHORITY, MUNICIPAL BUILDING DEPARTMENT, FIRE DEPARTMENT, ETC.) TO DETERMINE THE NEED TO OBTAIN A PERMIT FOR THE INSTALLATION.

POSTING OF NOTICES: Upon completion of installation and before the system is put into operation a “Notice” should be posted in the appliance room, near the outlet of the appliance. This “Notice” should contain, as a minimum, the information shown below:

NOTICE:

- The chimney liner to which this appliance is attached is Listed per CAN/ULC-S635 as a “Class 3 Lining System” for use in existing masonry or factory-built chimneys and vents. It may be used with oil, gas-fired equipment where the temperature of the flue gas products does not normally exceed 650°C (1200°F).
- The chimney liner to which this appliance is attached is Listed per UL1777 for use with gas fired equipment for flue gas temperatures up to 570°F continuous and short term exposure up to 1700°F.
- Under certain low ambient temperature conditions, some chimney caps can be susceptible to ice buildup. Check cap for ice buildup under such conditions and remove ice if necessary before using the chimney.
- Date of installation: (Fill in) \_\_\_\_\_
- Chimney Liner is Model EPS manufactured by ENERVEX Inc.

### 1.10 TERMINATION

For EPS systems used as Special Gas Vents, the systems shall terminate above the roof level in accordance with the following requirements:

1. Five feet above the roof level or any adjacent flat roof, wall parapet or air intakes, and/or in accordance with the following NFPA 211 requirements.
2. Where chimney terminates at less than 10 feet from any adjacent ridge, wall or parapet, the chimney shall terminate at minimum 3 feet above the ridge, wall or parapet.
3. Where chimney terminates at more than 10 feet from ridge, wall or parapet, a minimum height of 2 feet shall be required above the ridge wall or parapet.

Vent systems that exit the structure through a sidewall or the like shall terminate in accordance with the following requirements:

1. Not less than 12 inches above the ground.
2. Located above the snow line in geographical areas where snow accumulates.
3. Not located in traffic areas, such as walkways, unless the venting system is at least 7 feet (2.13m) above the ground.

The installation of the venting system relative to appliances that incorporate combustion air inlet systems shall have a venting system that terminates:

1. 6 feet (1.8 m) or more from the combustion air intake of any appliance
2. More than 3 feet (0.91 m) from any other building opening, gas utility meter, service regulator, and the like.
3. Less distance if specified in the appliance's instructions.

The venting system shall not be routed into, through, or within any other vent such as an existing masonry or factory built chimney flue (exception: a masonry chimney flue may be used to route the venting system if no other appliance is vented into the same masonry chimney flue and the installation instructions specify such restrictions).

For EPS systems used as chimneys according to NFPA211, building heating appliance chimneys must terminate at least 3 feet above the highest point where it passes through a roof of a building and a minimum of 2 feet higher than any part of the building with a horizontal distance of 10 feet. There are exceptions to these requirements when a mechanical draft system is used and some listed appliances have other requirements, so it is recommended to consult with the authority having jurisdiction for actual requirements.

### 1.11 SURROUNDINGS / ENCLOSURE

PowerStack chimneys are primarily intended to be used in fire resistive, noncombustible surroundings or installed unenclosed. They are not intended for use in one or two story family residences.

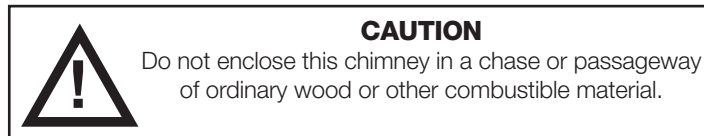

Where the chimney extends through any zone of a building outside the area in which the heating appliance connected to it is located, it shall be provided with an enclosure having a fire resistance equal to or greater than the fire rating of the floor, ceiling, wall or roof assemblies through which it passes.

All PowerStack models may penetrate a combustible roof using either the Insulated Roof Assembly or the Ventilated Roof Thimble. These are the only parts intended for use with combustible construction. All other parts, such as Plate and Wall Supports, and Floor and Wall Guides, are for attachment to non-combustible construction.

Where, according to local code, no chase enclosure is necessary, Model EPS1, EPS2 and EPS4 may be placed adjacent to walls of combustible construction at the minimum clearance specified on each pipe section and in the individual Listing; see CLEARANCES section and Tables 1-2 through 1-5. Contact local building or fire officials about restrictions and installation inspection requirements in your area.

### 1.12 MULTI-ENGINE EXHAUSTS

A common exhaust system for multiple engine or turbine installations is generally not recommended. Check with your engine or turbine manufacturer prior to common exhaust system design. Exhaust gas from operating units tends to flow to nonoperating units where condensation may form. Water in engine or turbines at start-up may cause damage. In general, a separate exhaust system should be provided for each engine or turbine.

**1.13 CLEARANCES**

See section 1.11 Surroundings / Enclosure. Model EPS is meant to be used as an option for “Unlisted Metal Chimneys (Smokestacks) for Non-residential Applications” and/or “Chimney Connectors and Vent Connectors” as defined in NFPA 211. All applicable NFPA 211 requirements must be followed regarding Uses, Clearances, Termination and Size.

	DO NOT WRAP OR PLACE INSULATION around these systems in an effort to reduce clearances to combustibles, create some type of fire protective enclosure or for any other purpose.
---	---

EPS Min. Airspace Clearance-to-Combustible (Unenclosed)					
Pipe ID	Building Heating Appliance Chimney (1,000°F)	Chimney Liner (Gas and Oil)	Special Gas Vent (550°F Rating)		Grease Duct
			Vertical 480°F Rating	Horizontal 480°F Rating	
4-8" (102-203mm)	18" (450mm)	See Sec. 1.9	2" (51mm)	3" (76mm)	See Section 11.6
10-14" (254-356mm)			3" (76mm)	3" (76mm)	
16" (406mm)			4" (102mm)	4" (102mm)	
18-24" (457-610mm)			5" (131mm)	5" (131mm)	

Table 1-2: EPS clearance to combustible  
\* Enclosed Vertical/Horizontal: DNA

EPS1 Min. Airspace Clearance-to-Combustible (Unenclosed)					
Pipe ID	Building Heating Appliance Chimney (1,000°F)	1,400°F Chimney	Special Gas Vent (550°F Rating)		Grease Duct
			Vertical	Horizontal	
4-10" (102-254mm)	1" (25mm)	1" (25mm)	0.5" (13mm)	1" (25mm)	See Section 11.6
12-14" (305-456mm)	2" (51mm)	2" (51mm)			
16-24" (406-610mm)	3" (76mm)	3" (76mm)			

Table 1-3: EPS1 clearance to combustible  
\* Enclosed Vertical: All sizes -1" (25mm) / Horizontal: DNA

EPS2 Min. Airspace Clearance-to-Combustible (Unenclosed)			
Pipe ID	Building Heating Appliance Chimney (1,000°F)	1,400°F Chimney	Grease Duct
4-10" (102-254mm)	1/2" (13mm)	1/2" (13mm)	See Section 11.6
12-14" (305-456mm)	1" (25mm)	1" (25mm)	
16-24" (406-610mm)	2" (51mm)	2" (51mm)	

Table 1-4: EPS2 clearance to combustible (Unenclosed)

EPS4 Min. Airspace Clearance-to-Combustible (Unenclosed)			
Pipe ID	Building Heating Appliance Chimney (1,000°F)	1,400°F Chimney	Grease Duct
4-14" (102-456mm)	1/2" (13mm)	1/2" (13mm)	See Section 11.6
16-24" (406-610mm)	1" (25mm)	1" (25mm)	

Table 1-5: EPS4 clearance to combustible

**1.14 PIPE WEIGHT**

Pipe weight is given in lbs/ft (kg/m) for each diameter. It is important to know the weight of the chimney section for chimney support and guiding.

Inside Diameter	EPS	EPS1	EPS2	EPS4
	lbs/ft (kg/m)			
4" (102mm)	1.94 (1.30)	3.80 (5.66)	6.55 (9.75)	10.79 (16.06)
6" (127mm)	2.85 (1.91)	5.15 (7.66)	8.00 (11.92)	12.49 (18.58)
7" (152mm)	3.30 (2.23)	5.83 (8.67)	8.73 (12.99)	13.40 (19.95)
8" (203mm)	3.76 (2.52)	6.50 (9.67)	9.50 (14.14)	14.29 (21.27)
10" (254mm)	4.66 (3.13)	7.86 (11.70)	11.18 (16.35)	16.79 (24.99)
12" (305mm)	5.58 (3.75)	9.22 (13.73)	12.49 (18.58)	18.65 (27.75)
14" (356mm)	6.48 (4.35)	10.59 (15.76)	14.73 (21.92)	20.50 (30.51)
16" (406mm)	7.39 (4.97)	12.73 (18.95)	16.30 (24.25)	22.37 (33.29)
18" (457mm)	8.30 (5.58)	14.14 (21.04)	17.87 (26.60)	24.22 (36.05)
20" (508mm)	9.21 (6.19)	15.59 (23.20)	19.45 (28.94)	26.06 (38.78)
22" (559mm)	10.12 (6.80)	17.03 (25.35)	21.02 (31.28)	27.93 (41.57)
24" (610mm)	11.03 (7.41)	18.48 (27.50)	22.60 (33.63)	29.78 (44.33)

Table 1-6: Pipe Weight by Model and Diameter



### 1.15 PIPE JOINT ASSEMBLY

PowerStack components have a flanged joint system with a male and a female end and a graphite gasket. The installation orientation is female end must always be positioned indicated on the labeling of each pipe section with an arrow. The arrow indicates the direction of the flow.

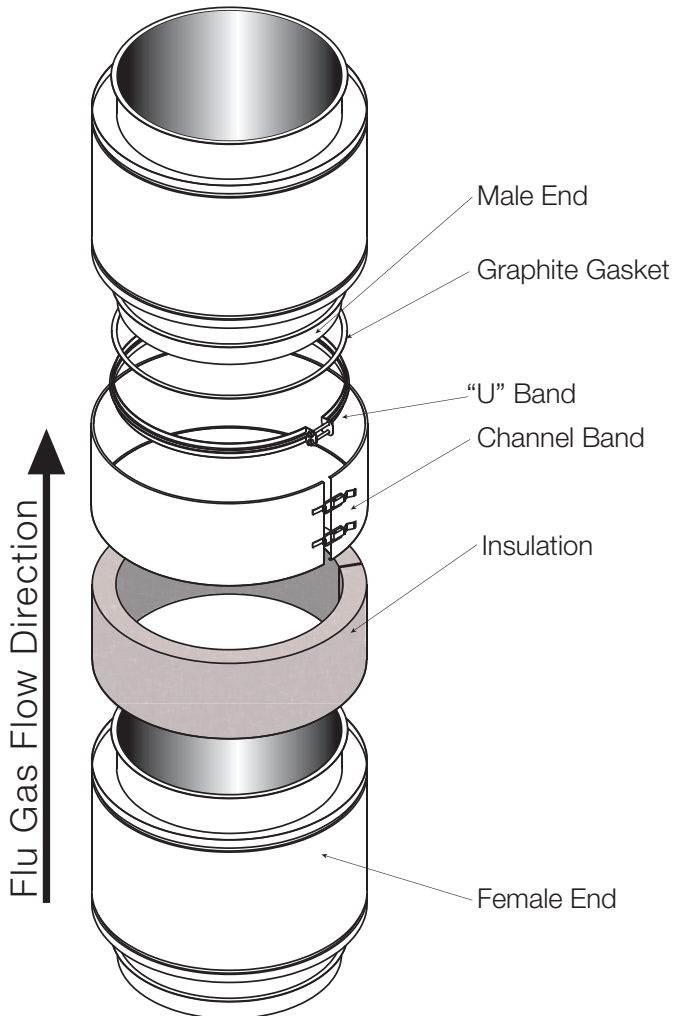

The channel bands are designed to slide in their mating grooves. Do not attach by screws into the outer casing. The snap locks is the only thing needed for proper assembly. Do not allow screws to penetrate the inner pipe. This can cause corrosion, gas leakage or expansion failure.

Never use screws through the outer jacket of a variable, adjustable length or bellows expansion joint. Observe adequate safety measures when using a reducer. Risk of injury. Sheet metal parts may be sharp. Always wear gloves and appropriate eye, foot, and other protection when handling these products.

1. Position male and female ends with graphite gasket accurately centered in between.
2. Position both faces of U-band together and LOOSELY connect one side with (2) bolts and nuts (supplied).
3. Carefully open U-band (from non-connected side) and manipulate U-band around joint flange, lightly seating U-band over flange joint, starting from connected side, working towards open end.
4. Again, starting from connected side, use a soft mallet (wooden or similar) to seat U-band over joint flange, alternating sides for even attachment while working towards open end.
5. Connect open end of U-band with (2) nuts and bolts (supplied) to snug fit, tighten previously attached side of U-band and alternate tightening sides until an even, tight application is achieved.
6. For EPS1, EPS2 and EPS4 models (insulated), insert the insulation strip (supplied) around the inner joint assembly at location shown in Fig 1-1. Secure insulation strip with tape (or similar) to keep insulation strip in position while completing joint assembly.
7. Position outer channel band edges of the band into the outer pipe grooves and drawing it closed with the two snap locks.
8. For vertical exterior joints apply clear sealant to the joint between the Channel Band and the outer pipe\*.

Fig 1-1: Pipe Joint Assembly

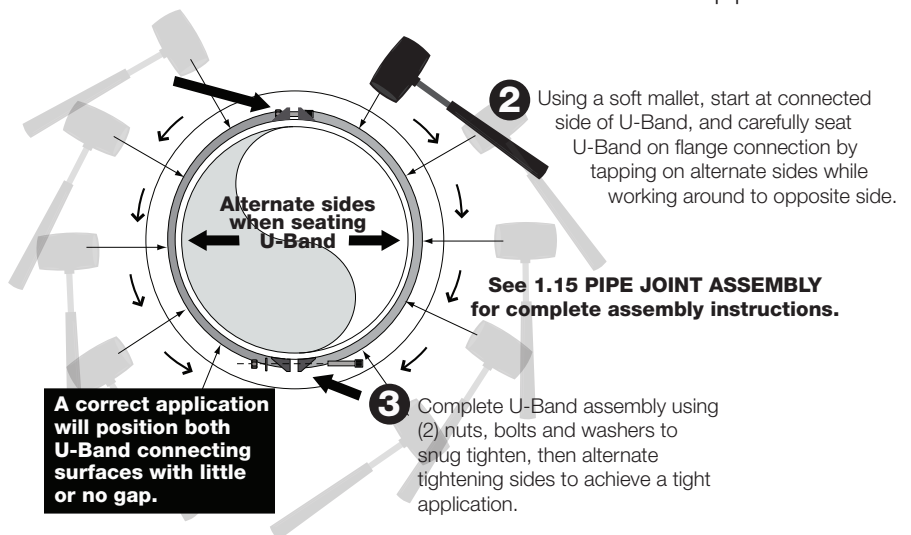
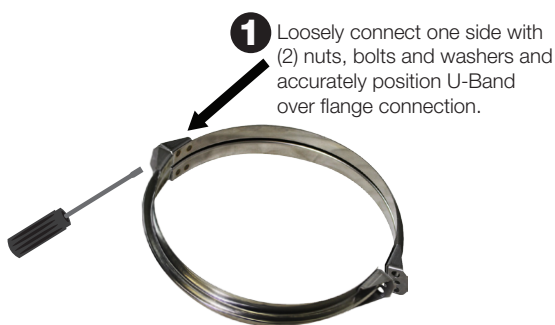

Fig 1-2: U-Band Application

**1.16 SUPPORT METHODS**

Several support and guiding methods are used to anchor the chimney against upward, downward and angular displacement. The supports and guides used with thermal expansion devices prevent bending stresses on the chimney elbows and joints.

**1.17 VERTICAL SUPPORT**

The maximum height limits for each support method is shown in Tables 1-7, 1-8 and 1-9.



Fig 1-2: Support Spacing

**1.18 VERTICAL GUIDE SPACING**

Full Rings are used in vertical installations as wall guides to maintain proper alignment of the system and are for lateral support for wind loads. The vertical freestanding height above the roof or top guide is limited due to wind considerations.

	MAX. HEIGHT ABOVE SUPPORT (A)			
	EPS	EPS1	EPS2	EPS4
4"-6" (102-150mm)	350' (106.7 m)	175' (53.3 m)	100' (30.4 m)	70' (21.3 m)
8"-12" (200-300mm)	350' (106.7 m)	175' (53.3 m)	100' (30.4 m)	90' (27.4 m)
14"-20" (350-500mm)	350' (106.7 m)	175' (53.3 m)	140' (42.6 m)	110' (33.5 m)
22"-24" (550-600mm)	350' (106.7 m)	175' (53.3 m)	140' (42.6 m)	120' (36.5 m)

Table 1-7: Height Limits for Plate Support

	MAX. VERTICAL GUIDE SPACING (B)			
	EPS	EPS1	EPS2	EPS4
All Diameters	13' (4.0 m)			

Table 1-8: Wall Guide Spacing Limits

	MAX. FREESTANDING HEIGHT ABOVE ROOF (C)			
	EPS	EPS1	EPS2	EPS4
4"-5" (100mm)	8.2' (2.5 m)			
6"-24" (150mm-610mm)	10.0' (3.0 m)			

Table 1-9: Unsupported Freestanding Length

**1.19 HORIZONTAL SUPPORT SPACING**

Horizontal installations or horizontal portions of vertical installations are supported primarily by use of Half Rings or Support Straps that are installed using minimum 1/2" threaded rod or structural steel provided by others. See Table 1-10 for maximum spacing between horizontal supports. Plate Supports are also used to support and stabilize the system at changes in direction and when using expansion sections.

	MAX. HORIZONTAL GUIDE SPACING			
	EPS	EPS1	EPS2	EPS4
All Diameters	13' (4.0 m)			

Table 1-10: Horizontal Support Spacing

## 1.20 THERMAL EXPANSION

Good installation practice requires that any length of exhaust system between two fixed points subject to more than 0.25 inch (6mm) expansion must be compensated by using an Adjustable Length or a Bellows Joint depending on the maximum pressure encountered.

It is essential that these parts be properly installed and provided with adequate guidance to prevent binding or excessive bending forces.

The exhaust system designer must be aware that the inner joints have negligible flexing capability, and in addition, Tees and Elbows are not designed to withstand excessive bending forces. Because the amount of outer casing axial movement is less than the inner casing movement, but still significant, the outer jackets of piping and Adjustable Lengths must also slide to avoid excessive forces on Tees, Elbows or Fixed Joints. To accommodate outer casing movements, external guides along walls, at floors, or in lateral breechings, must allow for movement of the pipe. Further; Full/Half Rings, Wall Guides or Floor Guides must be so located that Outer Channel Band movements will be away from the ring.

For engine or turbine exhaust systems requiring pressures up to 60 inches of water column, or where the construction must be absolutely gas tight, all welded bellows Expansion Joints, either with a liner or without a liner are recommended for expansion and vibration movements of the exhaust piping.

Low pressure systems, such as boilers (up to 6 inches water column), can effectively use the expansion Length. Spacing of guides and supports, when a thermal expansion part is used, should not be greater than specified in Section 1. Table 1-7 through 1-10. Proper guiding and support of expansion parts often requires closer spacing.

It is important that any Guide Band or similar component is located at least 6" (150mm) away from the expansion component in order to prevent interference.

The Telescopic Flashing should always be used where the product is subject to vertical expansion through the roof.

Though thermal expansion can be calculated from the formula, a rule of thumb for exhaust pipe expansion estimation is that the axial growth will be approximately 1" per 100' of pipe length (1mm per 1 meter pipe length) for each 100°F (50°C) the flue gas temperature difference between flue gas and surrounding air ambient temperature.

$$\Delta E \text{ (mm)} = EC (0.016) \times \Delta T \text{ (}^{\circ}\text{C)} \times \text{Pipe Length (Meters)}$$

where  $\Delta T \text{ (}^{\circ}\text{C)} = \text{Exhaust Temperature Rise above Ambient Temperature}$

Ex.: Thermal Expansion for 30 meter of pipe at 540°C and 16°C ambient

$$\Delta E \text{ (mm)} = EC (0.016) \times (540-16) \text{ (}^{\circ}\text{C)} \times 30 \text{ (Meters)}$$

$$\Delta E \text{ (mm)} = 251 \text{ mm}$$

Fig 1-3: Formula for Thermal Expansion -  $\Delta E$  (Metric)

$$\Delta E \text{ (in.)} = EC (0.0000089) \times \Delta T \text{ (}^{\circ}\text{F)} \times \text{Pipe Length (inches)}$$

where  $\Delta T \text{ (}^{\circ}\text{F)} = \text{Exhaust Temperature Rise above Ambient Temperature}$

Ex.: Thermal Expansion for 100' of pipe at 1000°F and 60°F ambient

$$\Delta E \text{ (in.)} = EC (0.0000089) \times (1000-60) \text{ (}^{\circ}\text{F)} \times 1200 \text{ (inches)}$$

$$\Delta E \text{ (in.)} = 10.04 \text{ in.}$$

Fig 1-4: Formula for Thermal Expansion -  $\Delta E$  (Imperial)

### 1.21 CHIMNEY GUYING AND BRACING

PowerStack has thin pipe walls relative to its diameter ( $t/D < 0.006$  for all sizes) and has the characteristics of a continuous pipe of 300 Series Stainless Steel. Therefore it will expand and contract along its entire length with changes in temperature. Unless properly supported and guided, structural damage to the exhaust system will occur. Conventional methods of attaching guides and braces to the outer pipe cannot be used. Correctly installed Angle Rings, Wall Guides, Floor Guides, Guy Sections, Plate Support Assemblies and Wall Support Assemblies will serve to keep the chimney aligned and supported, provide for adequate wind load resistance and allow for axial thermal expansion and contraction.

Stabilization of the part of the chimney which extends above the roof or a parapet wall requires special consideration. For low, freestanding installations (Table 1-9) the chimney needs no special guying or bracing. However, to protect the roof flashings from loads caused by wind against the exposed chimney, the installation must be stabilized with a Guy Section Assembly as illustrated in Fig 7-9.

In addition to the requirement for alignment and stabilization of the chimney, the need often exists for guying or otherwise bracing taller chimneys to resist upsetting forces. For this a Guy Section is used. It consists of two pieces of standard 18 inch long pipe welded together and rigidly captured between two heavy duty steel flanges that are welded together about their entire perimeter. With holes every 30°, the heavy duty attachment allows great flexibility of multiple cable guys (a minimum of three). In all but the simplest installation, contact the factory for complete guy tension and preload calculations.

Contact factory for additional design assistance. The purpose of guying or bracing is to prevent wind effects from developing excessive bending forces or horizontal displacements in exposed chimneys. This means that cables which are attached to the guy section must be slightly slack or loose, allowing for thermal expansion to occur without damaging fasteners or attachments. Some stack configurations require spring loaded Guy Tensioners to preload the guy cables for a satisfactory installation. These displacement limiting tension devices must be incorporated in cable guys if expected thermal expansion exceeds allowable slack in the cables.

For stack heights above the roof requiring guy wires or rigid bracing to minimize thermal expansion effects, a Plate Support Assembly or Wall Support Assembly must be installed at or near the roof line. If necessary, Guy Tensioners should be used.

The height limit of a PowerStack stack above the roof can be found in Table 1-9.

### 1.22 SEISMIC REQUIREMENTS

In certain areas of the country, local codes contain requirements to address seismic risks. Seismic requirements for chimneys and grease ducts usually include specifications for additional "sway bars" / bracing, or similar devices in order to help stabilize the system in the event of an earthquake.

Specific guidelines (including spacing, location, size and method of attachment of bracing / sway bars or other devices) for addressing seismic requirements vary depending upon the adopted code, seismic zone, duct size, location in building, etc. and are not within the scope of these installation instructions.

Consult with a design professional in order to determine compliance options for these potentially complex requirements when this product is to be installed in a building where these additional requirements apply.

The support methods described in these instructions have been proven adequate (via UL certification) for locations where there are no additional seismic zone requirements. In order to address additional seismic requirements they may be further supplemented with a variety of generic sway bars or braces that attach to or around the outer wall of the grease duct system. Full Angle Rings, Half Angle Rings and Support Straps may be included as components of such supplemental bracing.

## 2. CONNECTION AND ADAPTERS

### 2.1 UNIVERSAL BOILER KIT ADAPTER

A Universal Boiler Kit Adapter is designed to connect a chimney to a boiler or other appliance having a flanged outlet with a 4, 6, 8 or 12 bolt hole pattern. The Boiler Adapter is a flat 1/4" thick steel ring supplied in two half-circle pieces with twenty four 3/8" x 1" slots equally spaced around the face of the adapter (See Fig 2-1). To Install:

1. Apply a continuous bead of sealant to the face of the pipe flange and to the boiler flange.
2. Align the pipe flange with the appliance and position one half of the Boiler Adapter Ring over the pipe's inner wall flange, aligning the bolt slots with bolt holes in the boiler and secure ring with bolts.
3. Install second half of the ring as described in step 2.
4. Tighten all nuts and bolts in an alternating pattern until the pipe flange is seated firmly between the boiler and the adapter.

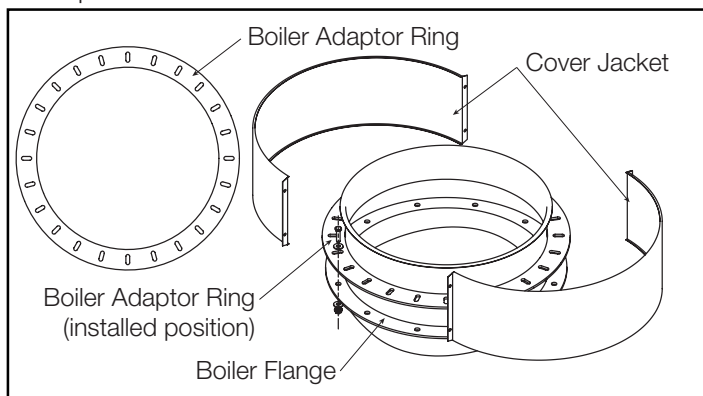

Fig 2-1: Universal Boiler Kit Adapter

### 2.2 FLANGED BOILER KIT

Use this component to connect the flanged end of any PowerStack element onto the boiler flanged flue gas outlet.

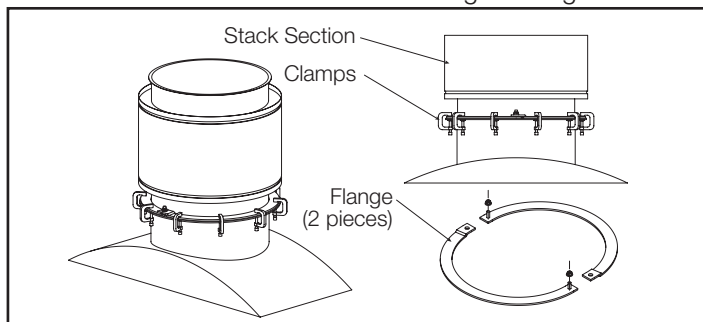

Fig 2-2: Flanged Boiler Kit

1. The two halves must be lined and bolted to make the appropriate ring around the exposed liner above the flange.
2. Apply appropriate sealant to inside faces of flanges.
3. Position flanges together and secure with the appropriate number of clamps located at equal distance around the flange circumference.

### 2.3 FLANGE ADAPTER KIT

The Flange Adaptor is manufactured to the customer's requirements as detailed at time of order. This component consists of a 3.34" (85mm) length of liner, one Cover Jacket, one custom made full flange and one split flange.

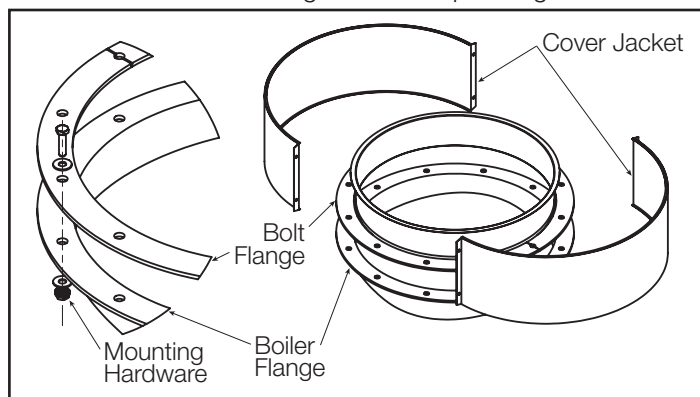

Fig 2-2: Flange adapter

A continuous bead of appropriate sealant is applied around the appliance flange. The full custom made flange is then located and aligned over the appliance flange. A continuous bead of appropriate sealant is then applied around the liner flange face and the purpose made flange and aligned. The two sides of the split flange are then located over the liner flange and aligned with the holes in the mating flange. Nuts and bolts are then inserted and loosely tightened. Once all nuts and bolts are located, tighten all nuts in an alternating pattern until the pipe flange is seated firmly between the Flanged Adaptor and appliance.

The flange adapter can be custom made for connections to other standard Flange Adapters for economizers, fans, dampers etc.

### 2.4 APPLIANCE CONNECTOR

This is a 6" (150mm) length of liner flanged at one end only. Secure to any PowerStack element in the conventional manner, and utilize/connect the protecting collar to the appliance as required.

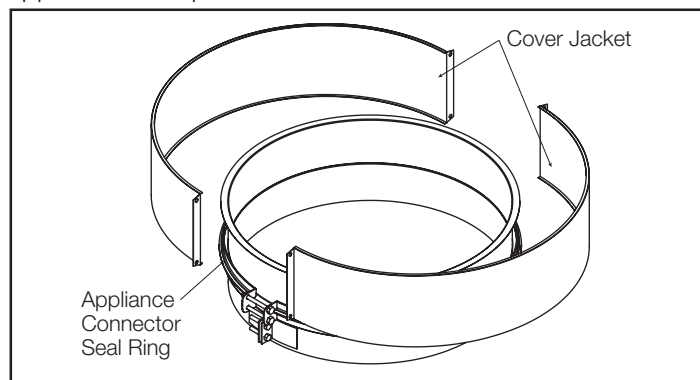

Fig 2-4: Appliance connector

**2.5 FLANGE ADAPTER - ANSI 125/150**

This component is a short liner length with a standard flange at one end and an ANSI 125/150 bolt flange attached at the other end. Can be connected to another ANSI 125/150 bolt flange whether on a generator, engine, boiler or other appliance.

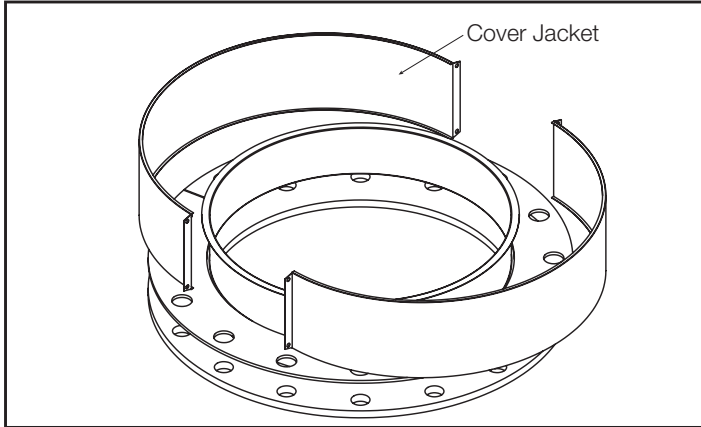

Fig 2-5: Flange Adapter - ANSI 125/150

**2.6 HOOD TRANSITIONS**

The hood transition stubs are single wall liners with flanges in both ends or in one end only. They can be welded directly to the hood or to a transition which has been fabricated to match the opening in the hood.

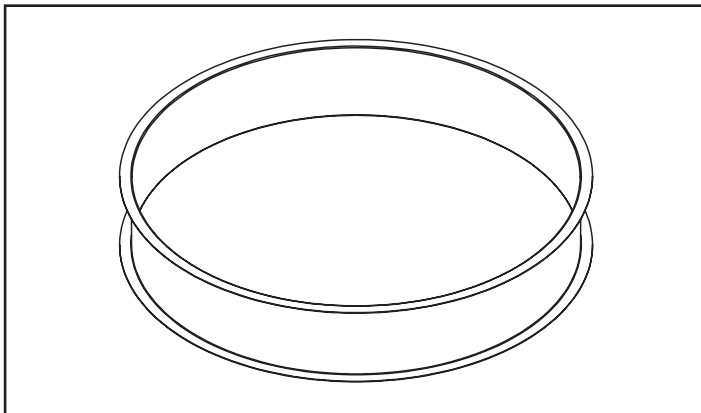

Fig 2-6: Flanged Hood Transitions

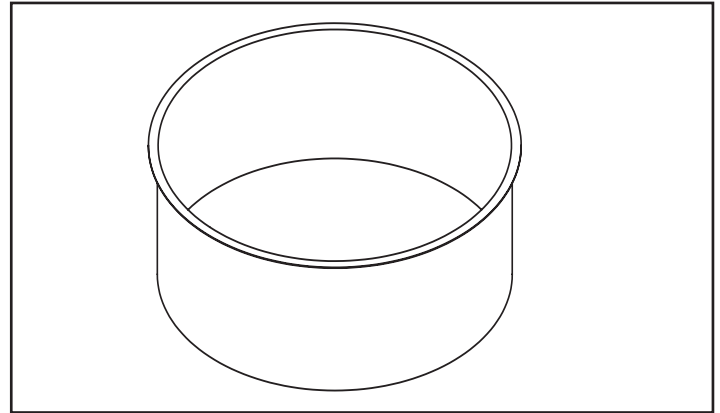

Fig 2-7: Unflanged Hood Transition

**2.7 TRANSITION TO ROUND**

This component is used to connect to and from a rectangular or square outlet on kitchen exhaust hoods. It is custom made for project requirements.

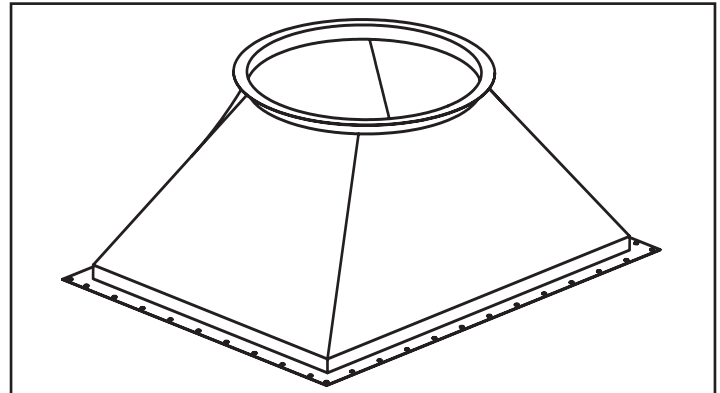

Fig 2-8: Rectangular to Round Transition

**2.8 SPECIAL ADAPTERS**

ENERVEX designs and fabricates custom-made adapters for virtually any boiler, generator or appliance.

### 3. STRAIGHT LENGTHS

#### 3.1 PIPE LENGTHS

The PowerStack is available in various lengths. These are standards:

- 10" (245mm)
- 20" (510mm)
- 30" (775mm)
- 40" (1040mm)
- Short Adjustable Length
- Long Adjustable Length
- Unlined Bellow Joint
- Bellows jacket (S/S)
- Adapter Stub (316)

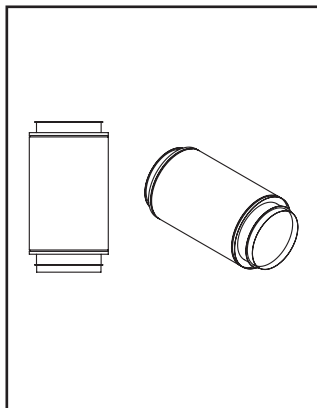

Fig 3-1: Pipe Lengths

#### 3.2 LENGTHS WITH NOZZLE/TEST PORT

All standards lengths are also available with 2 test ports with 1" NPT stainless steel nipple.

- 10" (245mm) w/2 test plugs
- 20" (510mm) w/2 test plugs
- 30" (775mm) w/2 test plugs
- 40" (1040mm) w/2 test plugs

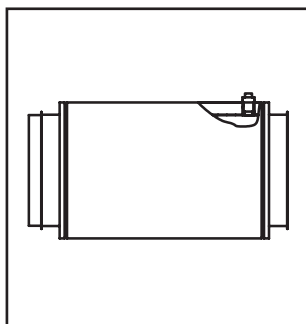

Fig 3-2: Lengths with Nozzle/Test Port

The practice of NFPA 96 concerning fire safety requires that fire extinguishing equipment shall be provided for the protection of duct systems, grease removal devices and hoods, especially if all the cooking equipment is not served by Listed grease extractors.

The use of a special Pipe Section with Port/Nozzle allows various types of fire extinguishing equipment to be integrated into the grease duct work, if necessary.

The Nozzle Section (See Fig. 3-2) can be positioned so that the nozzle fitting is either on the sides or top of the section consistent with good fire protection design practice. Various diameter NPT couplings offered allow for flexibility when making the required connections.

#### 3.3 DRAIN SECTION

For use with open vent terminations for draining off of condensate from inside the vent. Should be located inside the building to protect against freezing. When required, it can also be used as a horizontal drain section installed in the horizontal section of the chimney. Includes a U-Band and a cover jacket. The Drain Section incorporates a 1" NPT stainless steel nipple with protective plastic cap.

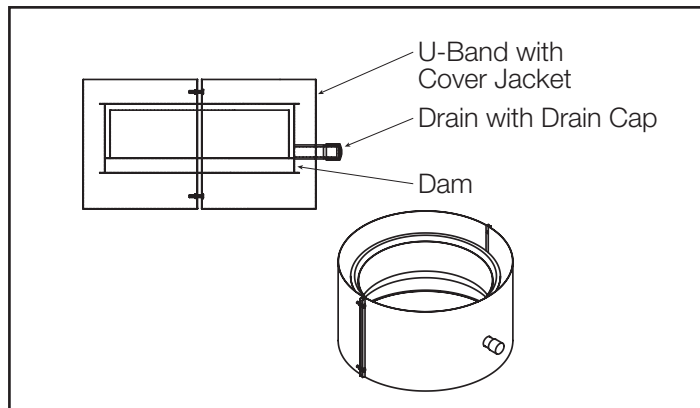

Fig 3-3: Drain Section

## 4. THERMAL EXPANSION, ADJUSTABLE LENGTHS, BELLOW JOINTS

### 4.1 ADJUSTABLE LENGTHS

The Adjustable Length is designed to serve two purposes - make up odd lengths of pipe as needed with short lengths and as an expansion joint to accommodate expansion in low pressure / low temperature applications. The adjustable length can be used in applications where the temperature does not exceed 1400° F and the positive pressure does not exceed 60" WC.

Based on temperature and length, if more than 1/4" of thermal expansion is expected in the horizontal run between an appliance connection and a tee, the use of two axis support is recommended. This enables the Adjustable Length to absorb expansion movement and prevents distortion or damage to the Tee.

Allowable lengths for 1/4" thermal expansion:

Gas Temperature Rise	Length (mm)
200°F	12'6" (3810 mm)
300°F	8'4" (2530 mm)
400°F	6'3" (1905 mm)
500°F	5'0" (1524 mm)
600°F	4'2" (1270 mm)
700°F	3'7" (1092 mm)
800°F	3'1" (940 mm)
900°F	2'9" (838 mm)
1,000°F	2'6" (762 mm)

Table 4-1: Thermal Expansion Rates

The Adjustable Length comprises a sliding inner section, flange on one end only (see Fig 4-1). This sliding piece is sized to fit closely inside a standard pipe section. At the sliding joint the assembly is fitted with a special graphited packing seal.

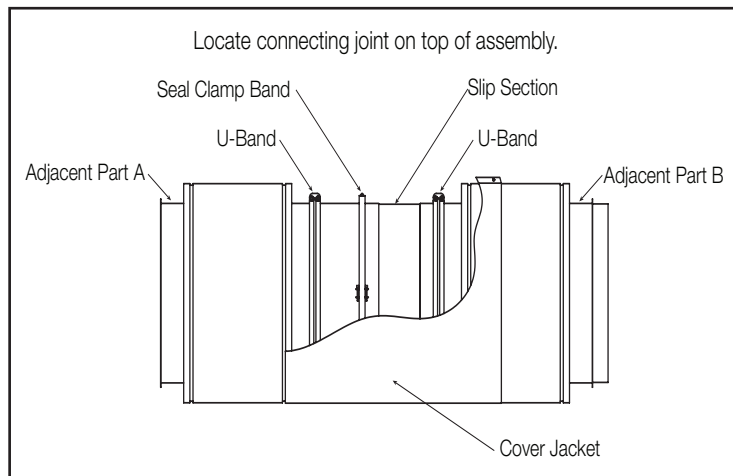

Fig 4-1: Adjustable Length Assembly Details

The sliding outer jacket is the same thickness as that used on piping outer casing. It is placed around the sliding inner joint and must also slide in order to avoid expansion stress.

For proper installation, an Adjustable Length must have adequate overlap and sufficient allowance for thermal expansion movement (see Fig 4-1).

If an Adjustable Length Assembly must be installed next to a fitting, the adjustable Length sliding inner section may be trimmed to ensure correct mating to a fitting or other short part. Care must be exercised so that proper penetration is maintained at low temperatures and no interference occurs at high temperatures.

For installation, join Adjacent Part B to the Adjustable Length and apply and tighten the U-Band to complete the joint.

Apply the insulation blanket around the circumference of the liner. It is important to ensure that the insulation joints are overlapped and a final check should be made to ensure that full integrity of insulation is maintained over the section.

Locate the cover jacket in the groove of Adjacent Part A. The lower end of the cover jacket lies flush over the preceding Adjacent Part B to allow for expansion. Secure the cover jacket in place using the hardware provided with the assembly on the underside when installed on horizontal runs.



The table below shows the MIN and MAX lengths of the Adjustable Lengths:

Diameter inch (mm)	Adjustable Length			
	Short - 20"		Long - 30"	
	Min	Max	Min	Max
4.0" (102mm)	6.0" (150mm)	16.0" (405mm)	6.0" (150mm)	26.0" (660mm)
6.0" (150mm)		16.0" (405mm)		26.0" (660mm)
7.0" (180mm)		16.0" (405mm)		26.0" (660mm)
8.0" (200mm)		16.0" (405mm)		26.0" (660mm)
10.0" (250mm)		16.0" (405mm)		26.0" (660mm)
12.0" (305mm)		16.0" (405mm)		26.0" (660mm)
14.0" (355mm)		16.0" (405mm)		26.0" (660mm)
16.0" (405mm)		16.0" (405mm)		26.0" (660mm)
18.0" (455mm)		16.0" (405mm)		26.0" (660mm)
20.0" (505mm)		16.0" (405mm)		26.0" (660mm)
22.0" (560mm)		16.0" (405mm)		26.0" (660mm)
24.0" (610mm)		16.0" (405mm)		26.0" (660mm)

Note: The dimensions do not make allowances for thermal expansion, which requires the MIN dimension to be increased if the component is assembled almost closed.

#### 4.2 VERTICAL INSTALLATION OF BELLOWS AND ADJUSTABLE LENGTHS

When a Bellows Joint or an Adjustable Length is installed in a vertical position between two fixed points, it should be installed immediately below or one pipe length below the higher support. To assure proper axial alignment, guides must be installed at the pipe section below the Bellows or Adjustable Length.

#### 4.3 HORIZONTAL INSTALLATION OF BELLOWS AND ADJUSTABLE LENGTHS

Horizontal or sloped installations of Bellows or Adjustable Lengths use the same parts, assembled in the same relationship, as a vertical assembly. These adjustable joints, when required, may be placed anywhere between two fixed points of horizontal or sloped installation as long as they are properly guided, properly supported; and for sloped installations in particular, as long as bottoming out is prevented. It is recommended, but not required, that the Lined Bellows inner shield and the Adjustable Length sliding inner shield be attached to the upstream end of a horizontal installation (the free end is downstream, away from appliance). When the adjustable is put in place for horizontal runs, the packing joint must be on the top of the pipe.

#### 4.4 LINED BELLOWS LENGTHS

The lined bellows is used for high temperature applications, such as engine exhaust, and for exhaust pressure to 60 inches of water column. Bellows are recommended to allow for expansion and vibrational movements of the chimney.

The use of the Lined Bellows Joints compensates for the axial expansion of the long horizontal run.

The Lined Bellows has a stainless steel liner to minimize turbulence. This part has limited lateral movement (1/8" max.) and lateral offsets and parallel misalignments should be eliminated.

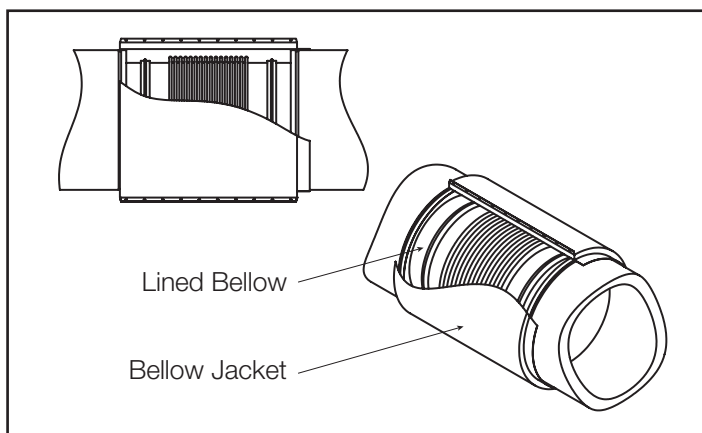

Fig 4-2: Lined Bellows Details

The Lined Bellows requires careful placement between rigid points to avoid interference on thermal expansion.

Note: At present (2015), Underwriters Laboratories (UL) has no Safety Standards for these devices, so although they are shown in this document and condoned by ENERVEX and others, UL has not independently investigated this product.

## 5. TEES, ELBOWS, INCREASERS, OFFSETS AND MANIFOLD, DRAINS

### 5.1 45° LATERAL TEE

Designed to provide connection, a change of direction and cleaning access if required. Can also be used to enable header connections to be made. May be ordered with a branch connection having a smaller diameter than main body.

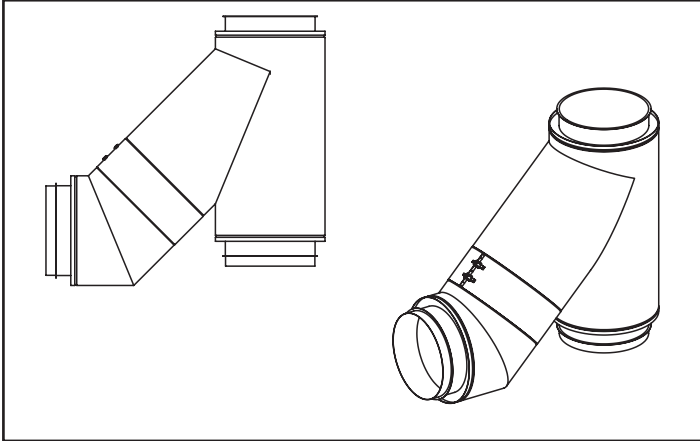

Fig 5-1: 45° Lateral Tee

### 5.2 90° AND 87° TEE

The 90° Tee is designed to provide connection, a change of direction and cleaning access if required. Can also be used in multiples for header configuration. The 87° Tee is used in condensing applications to provide a 3° slope to allow for the back flow of condensation through the system to a suitable drainage component.

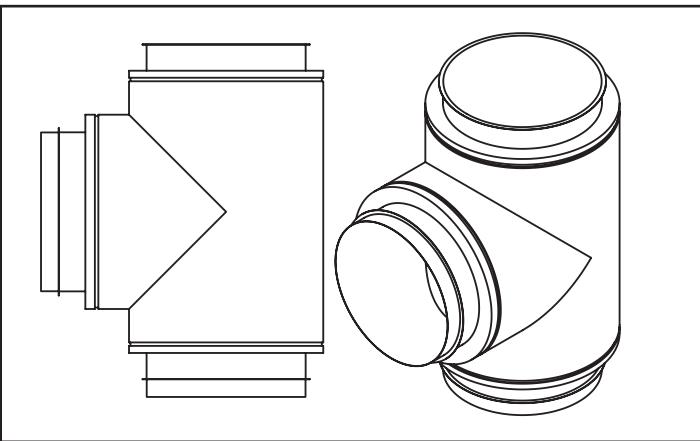

Fig 5-2: 90° Tee

Note: The 90° Tee should not be used on engine or turbine exhausts except when used as an inspection access where there is no change in flow direction.

### 5.3 3° 15°, 30°, 45°, 87°, 90° ELBOWS

Elbows are used to change directions. Can be used in singular or in combinations. Elbows must be protected from thermal expansion and bending forces. They do not bear load.

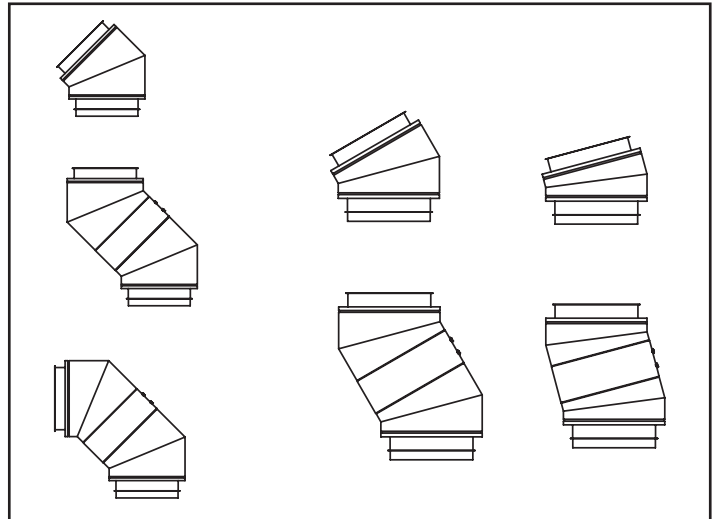

Fig 5-3: Elbows

### 5.4 DRAIN TEE CAP

The Drain Tee Cap is used as an end cap in horizontal runs, as an inspection fitting cover, and as a drain for vertical stacks. When not used as a drain the nipple shall be closed off with a pipe cap supplied by the installer. When used as a drain, a trap or a valve should be used in the drain line.

Always connect the drain fitting of the Drain Tee Cap to a suitable drain. This will allow rain entering the chimney to wash down, dilute and remove any corrosive combustion condensate. Also, always install the Drain Tee Cap with sealant on mating surfaces of the flanged joint as well as in the groove of the U-Bands. This will prevent leaks and assure that the drain functions as intended.

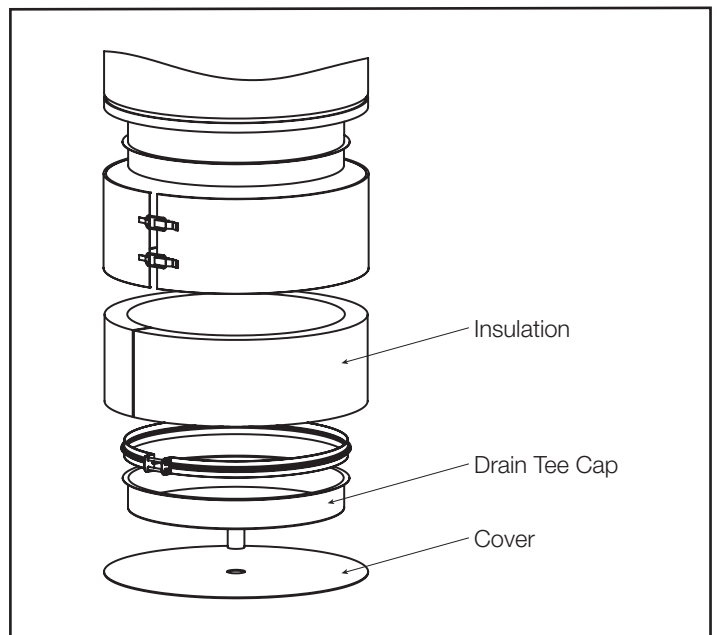

Fig 5-4: Drain Tee Cap

**5.5 TEE CAP**

Used to close off the unused opening of Tees and branched elbows where used for cleaning access.

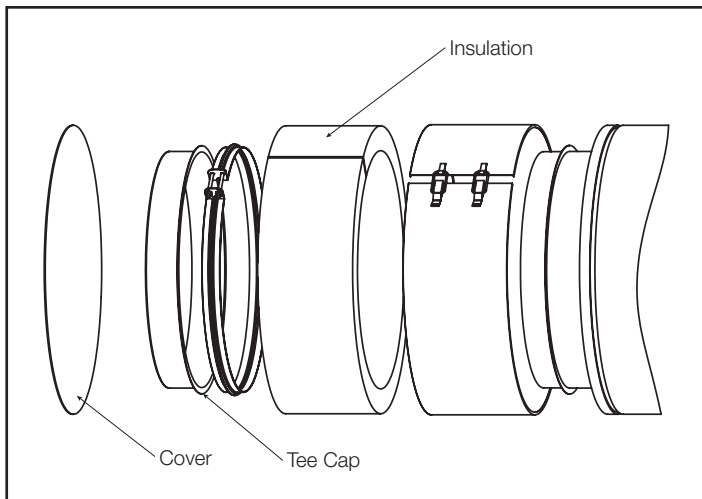

Fig 5-5: Tee Cap

**5.6 TAPERED INCREASER/REDUCER**

Tapered Increases are made with a standard side angle of 14° (28° included angle of cone) for low pressure losses, and provide an increases of one, two or three sizes.

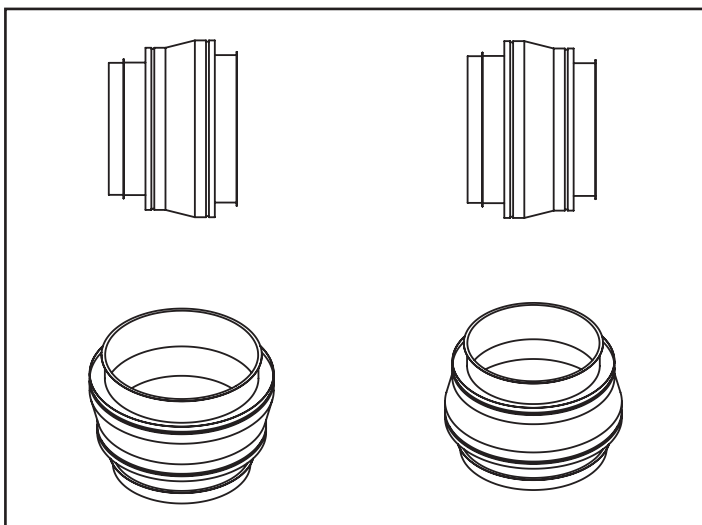

Fig 5-6: Increaser/Reducer

**5.7 STEP INCREASER/REDUCER**

Where space is limited, the Step Increaser provides the necessary increase, in a lineal distance of 2 inches from end to end. It should be installed so as to avoid deflection from static loads or thermal expansion forces. This is a non structural part and available in all steps.

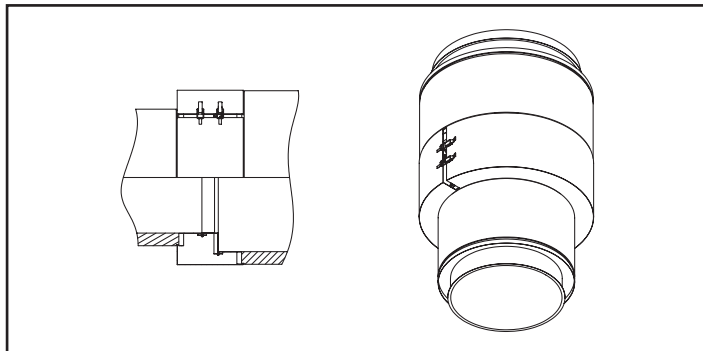

Fig 5-7: Step Increaser/Reducer

**5.8 STEPPED ECCENTRIC INCREASER/REDUCER**

The Stepped Eccentric Increaser keep the same low point and eases condensate or grease run off.

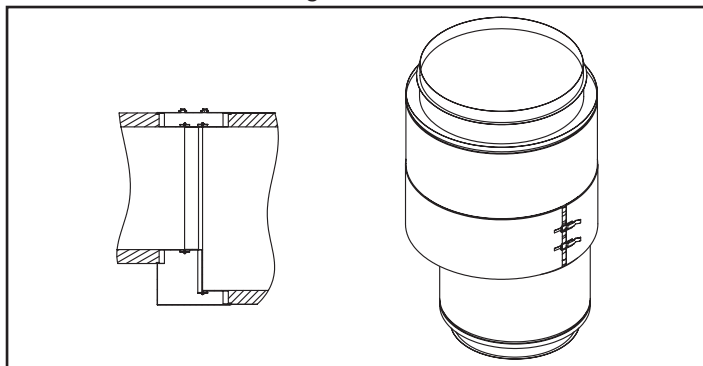

Fig 5-8: Eccentric Increaser/Reducer

## 6. TERMINATIONS

### 6.1 GENERAL

An upward discharge (such as with an Exit Cone or Open Top) provides the most effective means of dispersing chimney gases into the atmosphere and away from immediate surroundings. Such terminations however, will allow entry of rain unless there is upward flow at high velocity. A Stack Cap is only partially effective in excluding rain. Its effectiveness depends on chimney gas flow rate, raindrop characteristics and wind velocity.

With all chimney terminations, where rain may enter the chimney outlet, the following precautions must be taken:

1. All inner joints must be sealed with sealant.
2. Install a Vertical Drain Section at least 5 pipe diameters below the chimney outlet, but above any Tee or Elbow.
3. If a 90° or 45° Tee is used to catch rain, connect the Tee Cap drain fitting to a suitable drain. Use a trap in the drain if the system is under positive pressure.

Note: The Vertical Drain Section and Tee Cap Drain may both be used.

### 6.2 STACK CAP

The Stack Cap combines partial protection against rain entry with low exit flow resistance. (Resistance coefficient is roughly 0.05 velocity heads.) It is mounted to the end of a standard pipe section by use of the standard U-Band. A Closure Ring is provided as part of the Stack Cap so that the insulating air space is maintained through the upper end of the chimney.

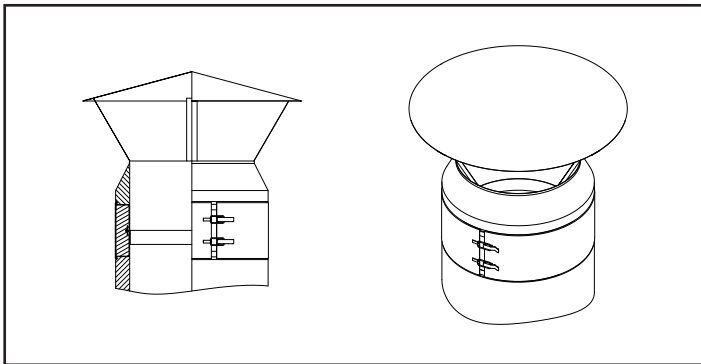

Fig 6-1: Stack Cap

Note: Do not use Stack Caps with engine, generator or turbine exhausts.

### 6.3 STACK CLOSURE SECTION

Installed at the vent system termination. It protects the system against water infiltration in the insulation between the inner and outer wall of the system.

The use of a Drain Section or Drain Tee Cap is necessary for this piece to collect any excess rain that may penetrate the vent.

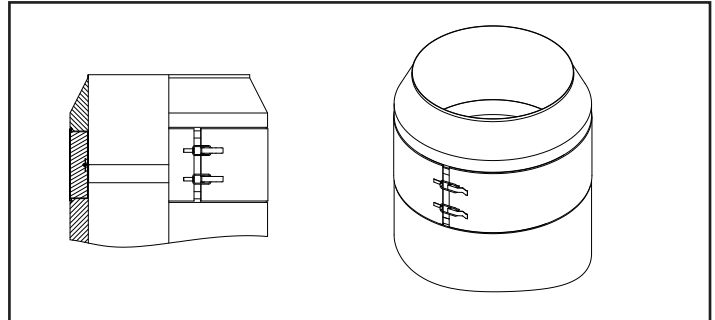

Fig 6-2: Stack Closure Section

### 6.4 MITER CUT SECTION

The Miter Cut is typically used with generator or engine exhaust. Secure to the horizontal discharge with a U-Band and Channel Band, and with the 45° slope facing down.

The Horizontal Exhaust Terminal can also be attached to a 90° Elbow where terminating horizontally from a vertical chimney stack.

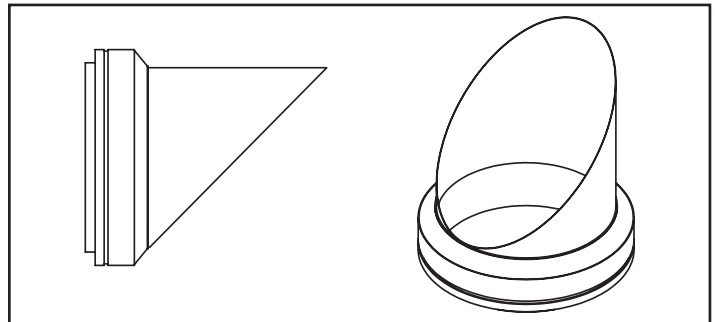

Fig 6-4: Mitre Cut Section

### 6.5 FAN PLATE ADAPTER

This termination section includes a heavy gage flat plate that is used to attach a termination mechanical draft fan or exhaust fan. Available in all flange sizes.

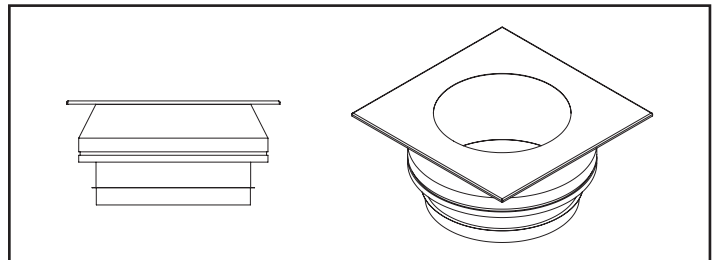

Fig 6-5: Fan Plate Adapter

## 6.6 FAN ADAPTER TERMINATION

The Fan Adapter Termination is a section of a EPS grease duct that incorporates a fan curb and provides a surface for mounting and installing an up-blast discharge fan. The Fan Adapter Termination eliminates the need for a separate welded fan curb termination assembly. The square curb is specifically designed to accommodate hinged type exhaust fans, commonly used for extraction of cooking fumes.

The Fan Adapter Termination also provides vertical support for the duct system and in some applications, when installed and supported properly, the weight of the hood and duct system may be suspended from the Fan Adapter Termination.

Note: At present (2015), Underwriters Laboratories (UL) has no Safety Standards for these devices, so although they are shown in this document and condoned by ENERVEX and others, UL has not independently investigated this product.

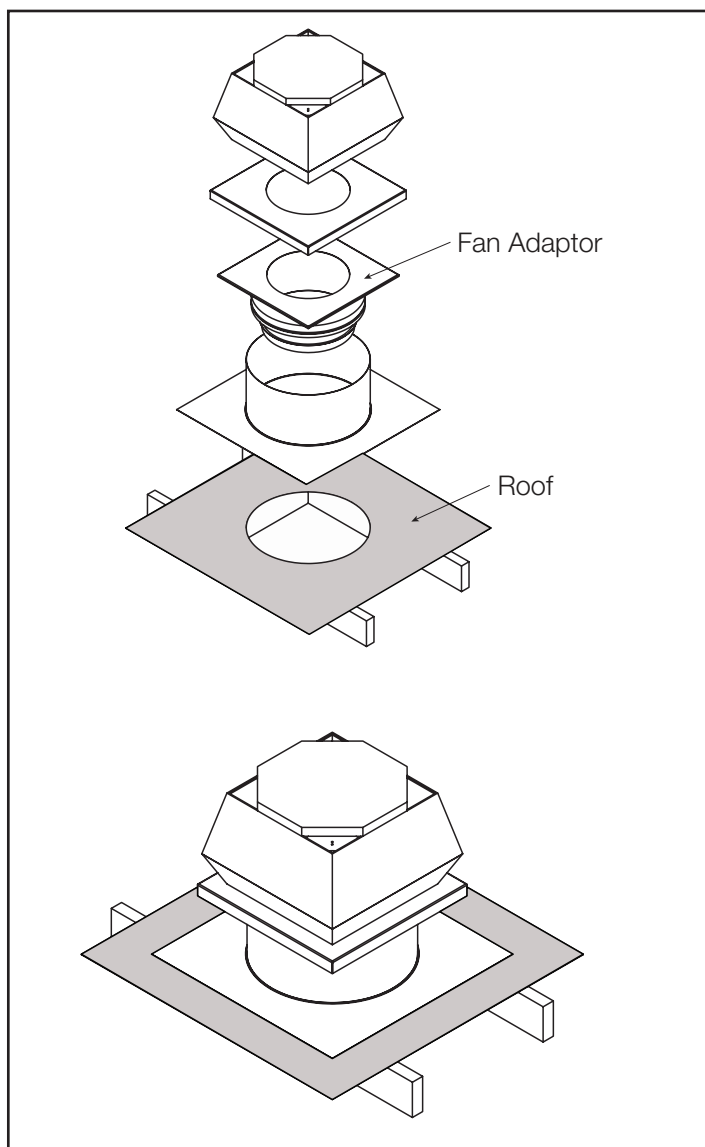

Fig 6-6: Fan Adapter Termination

## 6.7 FAN ADAPTER WITH ROOF CURB

This Fan Adapter is used, in many installations, to provide for the final connection between the grease duct system and an "upblast" fan. The adapter incorporates a square plate (on the top or outlet end) and a short section of duct incorporating a flanged end (on the bottom or inlet end). It is designed to set directly on top of the roof curb and directly beneath the fan base. (See Fig 6-7)

The Fan Adapter is first attached to the roof curb using bolts or screws through the square plate and into the curb. The inlet end connects to the remainder of the grease duct system using a U-Band and typical assembly methods described in 1.15 PIPE JOINT ASSEMBLY

A vented curb should be used if the roof construction being penetrated is of combustible construction.

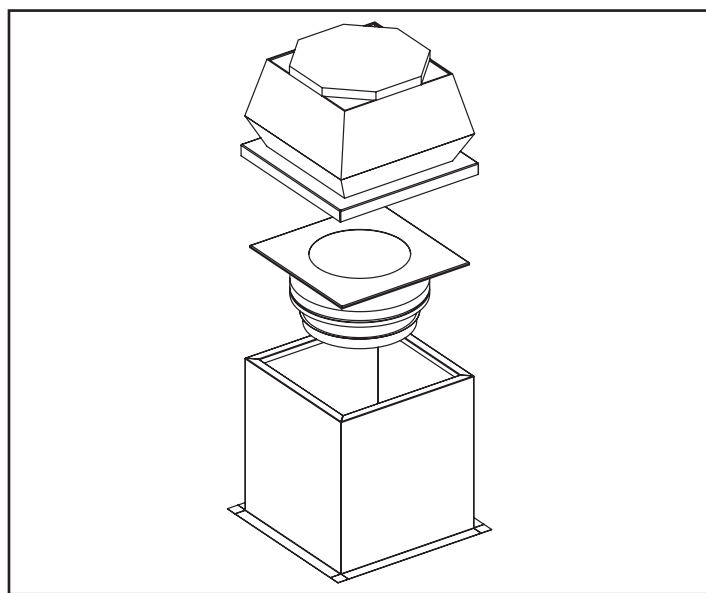

Fig 6-7: Fan Adapter with Roof Curb

Note: At present (2015), Underwriters Laboratories (UL) has no Safety Standards for these devices, so although they are shown in this document and condoned by ENERVEX and others, UL has not independently investigated this product.

## 7. STRUCTURAL SUPPORT AND GUIDE COMPONENTS

### 7.1 SUPPORT PLATE ASSEMBLY

The Support Plate Assembly consists of a 6 inch (170mm) installed length of liner flanged at both ends, and with a centrally located inner welded flange. Pairs of plates are assembled with half sections aligned 90° rotated on each side of central flange, and then bolted to adjacent steel framework on all four sides of the component.

The clamping force applied to the flange thus positioned is anchored against upward, downward and angular displacements.

The plate must be brazed back to the building structure or support with rigid structural members (by installer).

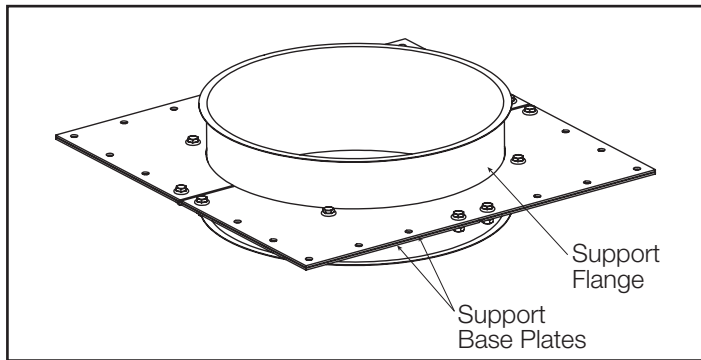

Fig 7-1: Support Plate Assembly

### 7.2 VERTICAL SUPPORT

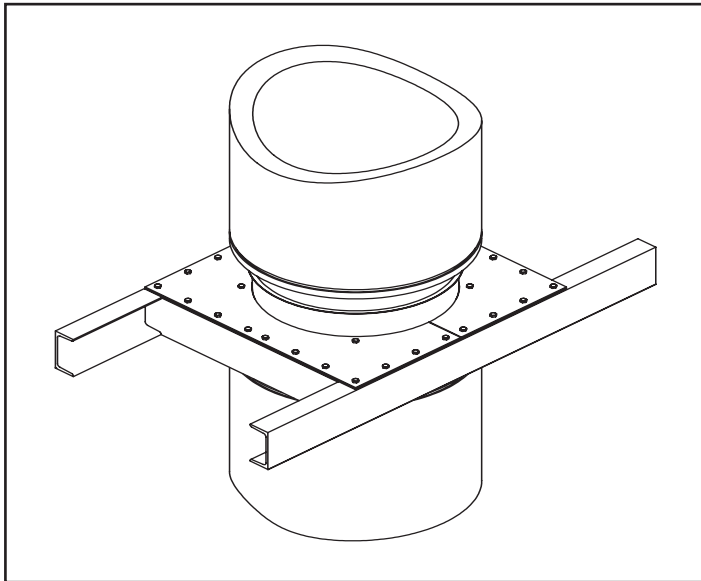

Fig 7-2: Vertical Support Plate

### 7.3 WALL SUPPORT

The Wall Support consists of the same plate support as the vertical support, but includes wall support bracing.

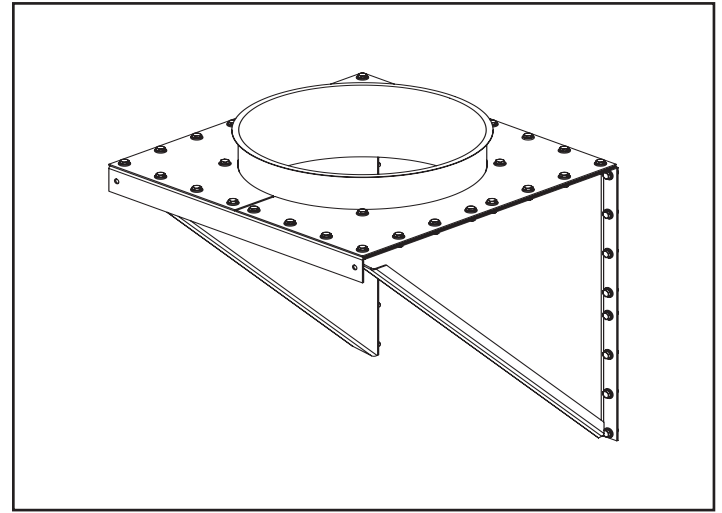

Fig 7-3: Wall Support Assembly

The Wall Side Support must always be positioned so that it is on the load bearing side of the trapped support flange. The assembly must be tightly bolted using all the nuts and bolts provided.

### 7.4 HORIZONTAL SUPPORT

Where used for horizontal frame work, lateral bracing is not supplied by ENERVEX.

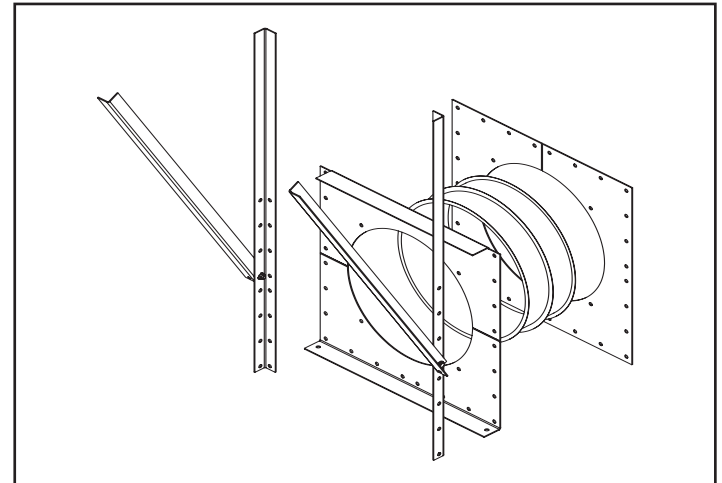

Fig 7-4: Horizontal Support

### 7.5 FLOOR GUIDE

The Floor Guide is used as a guide at a floor penetration. It is attached to the floor by means of (4) angle brackets. It maintains a minimum distance between the chimney and combustible floor material.

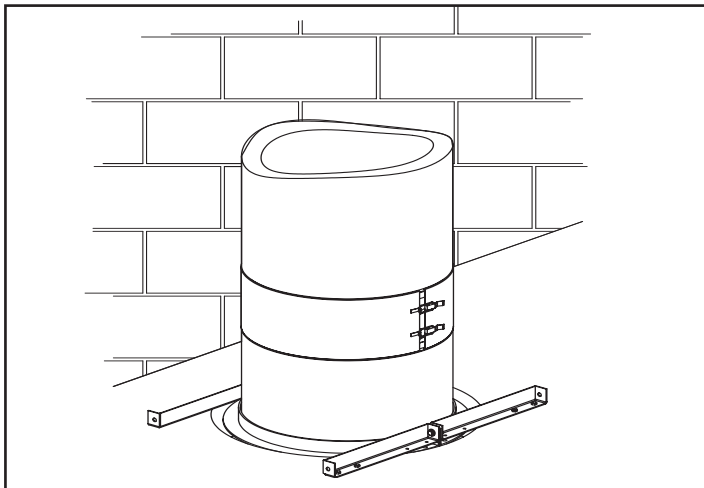

Fig 7-5: Floor Guide

Guide band should be located just below Channel Band for expansion allowance.

### 7.6 WALL GUIDE

This component uses a Full Angle Ring supplied with bracket, nuts and bolts for assembly. It does not include hardware for attachment to the structure. The latter must be provided by the installer and should be of sufficient and suitable strength to ensure adequate attachment.

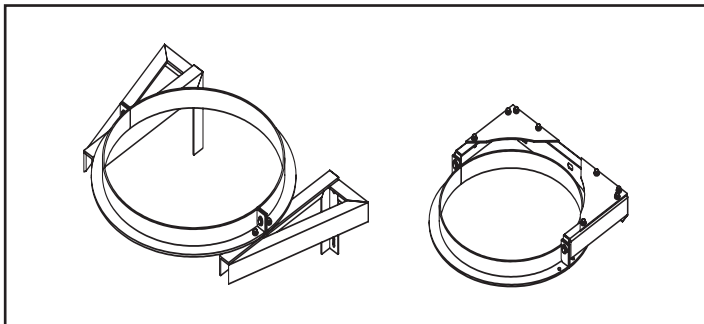

Fig 7-6 : Wall Guide

The Wall Guide is designed to provide 2 inch (55mm) clearance from the outer casing of EPS to non-combustible structures. The assembly is intended to resist lateral or side loads only, and must not be used to carry the weight of a vertical EPS system.

This assembly is not to be used for attachment to combustible structures. If the EPS must be attached to a combustible wall, spacers should be used to maintain minimum clearance required and also minimize heat conduction through supporting metal parts. The Angle Ring inside diameter is 0.2" (5mm) larger than the outside diameter of the EPS to allow for sliding movement during thermal expansion.

### 7.7 FULL ANGLE RING / HALF ANGLE RING

The Full Angle Ring may also be used as an expansion guide by attachment to a suitable structural steel frame. For a support cradle for horizontal run, half ring or Support Straps may be suspended by rods.

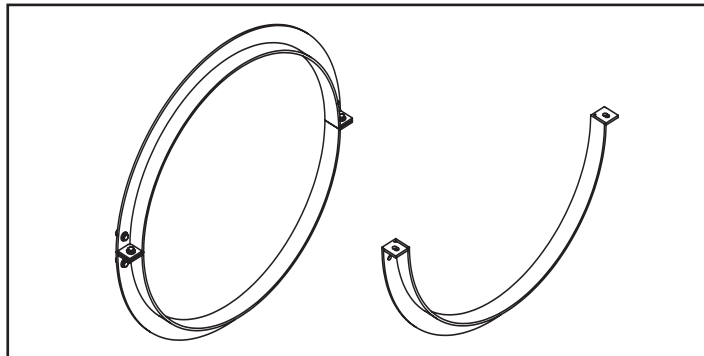

Fig 7-7: Full Angle Ring / Half Angle Ring

### 7.8 GUIDE BAND

The Guide Band is used as an expansion / lateral guide for EPS by attachment to suitable structure.

For horizontal applications, either a Guide Band or a Half Angle Ring may be suspended by rods or other types of rigid brace.

The Guide Band inside diameter is 0.2" (5mm) larger than the outside diameter of the EPS system to allow for sliding movement during thermal expansion.

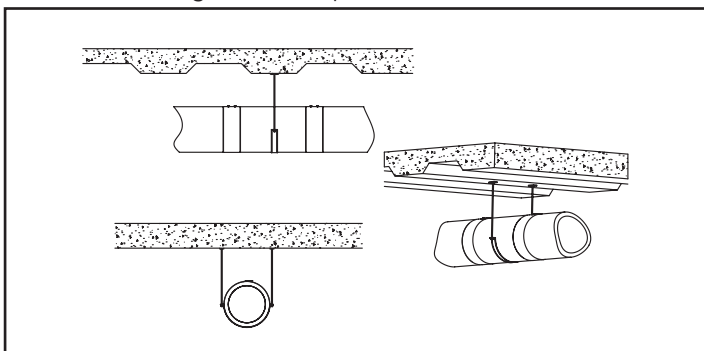

Fig 7-8: Guide Band

**7.9 GUY SECTION ASSEMBLY**

The Guy Section Assembly is used when the free-standing part of the chimney above the roof exceeds the limits according to table 1-7. At least three wires attached at the band perimeter, 120 degrees apart and secured to anchors on the roof are required.

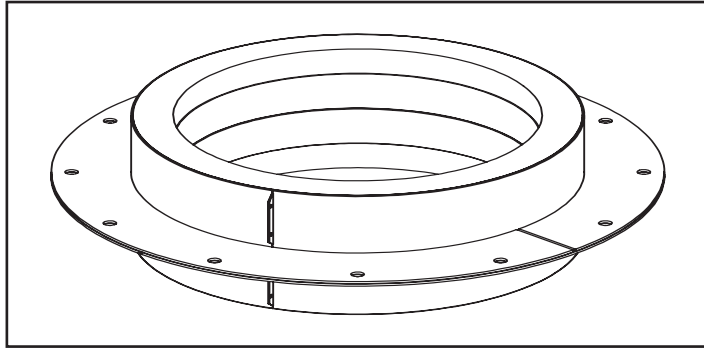

Fig 7-9: Guy Section Assembly

**7.11 CENTERING BAND**

Designed to insure proper centering of EPS inside a relined chimney. Should be used every 13 feet (4m).

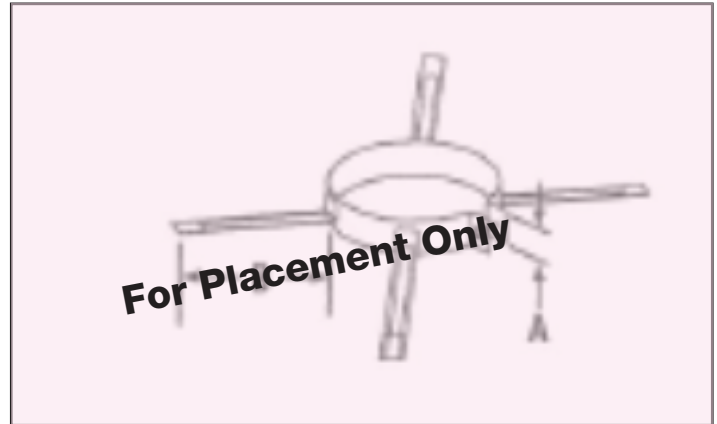

Fig 7-11: Centering Band

**7.10 SUPPORTING TEES AND ELBOWS**

Proper support of Elbows and Tees is critical. Both must be protected from thermal expansion and bending forces. Below are some structural alternatives for stiffening elbows using Plate Support or Wall Support components.

**CAUTION**

The Supports and Guides described here are only suitable for attachment to noncombustible construction.

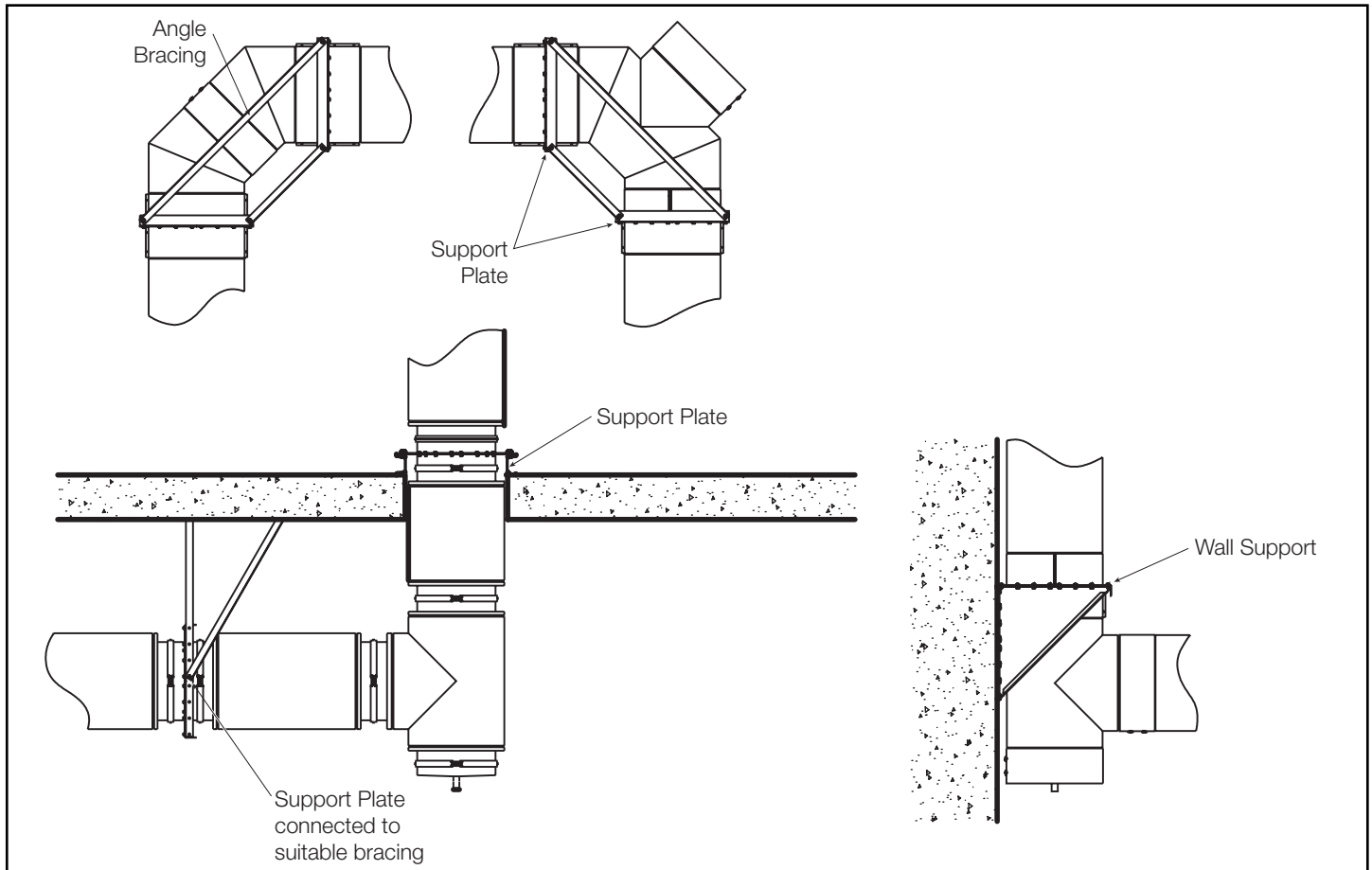

Fig 7-10: Supporting Tees and Elbows



## 8. ROOF PENETRATIONS, THIMBLES AND FLASHING

### 8.1 UNVENTED INSULATED ROOF ASSEMBLY

The insulated penetration thimble, which does not include a pipe section, is primarily for the penetration of building roofs and walls of combustible construction. It can be installed with a wooden frame at a minimum of 1" (25mm) clearance, see Fig 8-3 for framing data.

1. Before installation remove the top and bottom Lateral Support Rings from the insulated thimble.
2. The thimble mounts directly to a level combustible structure using four 1/4 x 2 1/2" lag screws and extends down through the roof void and into the space below. Where the roof is not level, build a suitable level frame construction above the roof to offer a flat and structurally stable platform for the insulated thimble assembly using the framing dimensions of Fig 8-3.
3. The pipe is then assembled from below and inserted through the insulated thimble assembly.
4. Position the upper and lower Lateral Support Band around the pipe and bolt through the hardware bracket on the thimble with the nuts and bolts provided.
5. Position the Floor Guide around the underside of the thimble, bolt together with the nuts and bolts provide and secure to the ceiling using appropriate lag screws.
6. The Flat Flashing is then passed over the upper section of pipe and position so that the flashing skirt is centrally located over the frame.
7. The flashing is then weathered in the traditional way depending on the type of roof.
8. Locate the Storm Collar around the pipe and loosely tighten the hardware. Ensure that the Storm Collar is positioned and located directly down on to the upstand of the Flat Flashing.
9. When in position, fully tighten the hardware and apply a bead of weather resistance sealant around the interface between the top of the Storm Collar cone and the overlap joint of the pipe in order to provide a suitable weather seal.

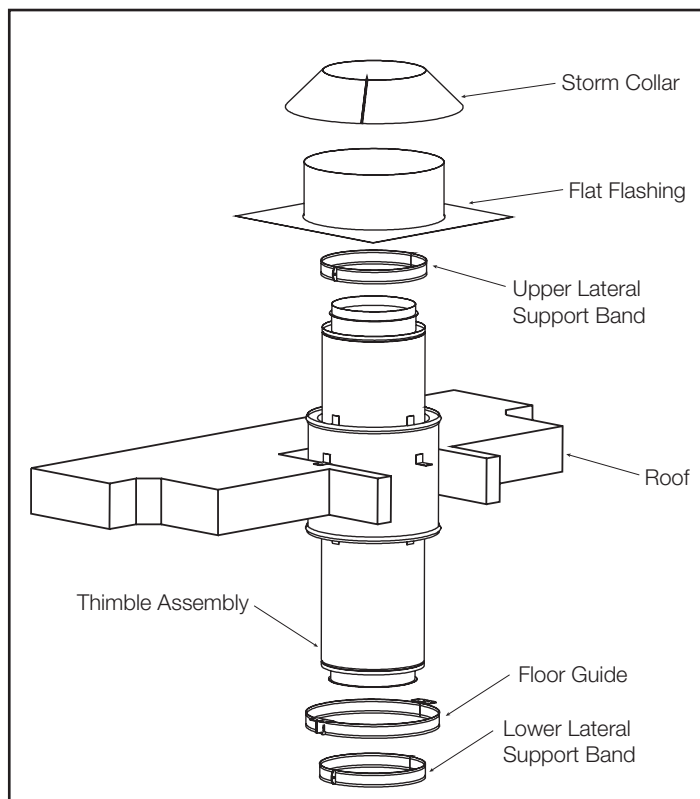

Fig 8-2: Roof Assembly Details

Expansion Note: There is approximately 0.2" (5mm) clearance between the OD of the pipe and the ID of the Lateral Support Band to allow for thermal movement of the pipe. Ensure that there is adequate vertical expansion allowance between the Pipe Channel Bands and the Upper and Lower Lateral Support Bands. Where possible ensure that any joint / Channel Band is located above the upper and lower Lateral Support Band to prevent interference. Failure to provide adequate allowance for expansion could seriously damage and compromise the integrity of the product.

Model	A
EPS 1	ID + 10" (250mm)
EPS 2	ID + 12" (300mm)
EPS 4	ID + 16" (400mm)

Fig 8-3: Framing Dimensions

## 8.2 INSULATED WALL FIRESTOP

The insulated wall firestop assembly is primarily used for wall penetration allowing a section to pass through a wall made of combustible material. It is used to maintain a minimum clearance between the combustible wall material and the chimney section passing through the wall. Follow these instructions for the installation:

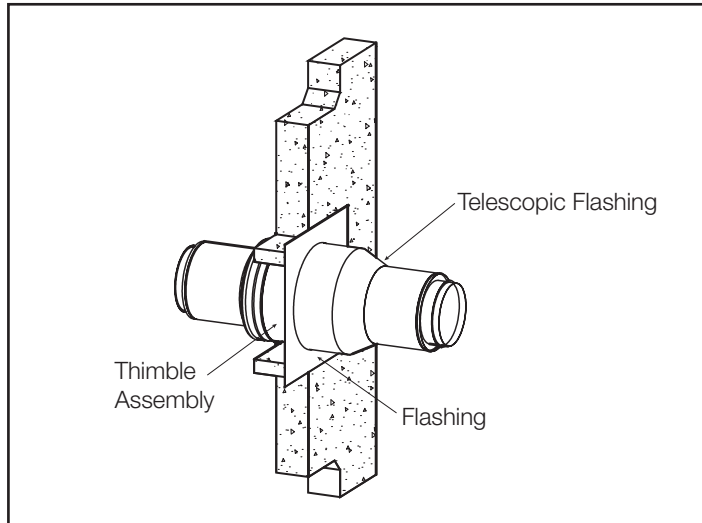

Fig 8-4: Insulated Wall Firestop

1. Create a framed opening in the wall insuring that the frame dimensions are as per Fig 8-3.
2. Install the thimble as per the instructions for the Roof Penetration.
3. Remove the upper and lower Lateral Support Band.
4. The pipe is then assembled and passed through the insulated thimble assembly.
5. Position the upper and lower Lateral Support Band around the pipe and bolt through the hardware bracket on the thimble with the nuts and bolts provided.
6. Position the Floor Guide around the thimble on the inside of the wall and bolt together with the nuts and bolts provide and secure to the wall frame using appropriate lag screws.
7. Position the Flat Flashing over the pipe on the outside wall and centralise with the frame. Secure and fix in position with suitable self tapping screws.
8. Position the Weathering Cone over the pipe and upstand of the Flat Flashing and using self tapping screws, fit in position.
9. Apply weatherproof sealant around the edge of the flat flashing base and also around the interface between the Weathering Cone and Flat Flashing Upstand.
10. Where single wall EPS is used on a gas vent system, use an EPS1 Insulated Wall Firestop section for the wall penetration and position the Storm Collar loosely over the pipe. Apply a bead of weatherproof sealant around the base of the cone on the weathering cone. Position the Storm Collar down over the Weathering Cone so

that it engages with the sealant. Secure and tighten the hardware on the Storm Collar. Where required, apply additional sealant to ensure adequate weathering of the assembly.

## 8.3 WALL FIRESTOP

This Wall Firestop assembly is primarily used for wall penetration allowing a section to pass through a wall made of combustible material. It is used to maintain a minimum clearance between the combustible wall material and the chimney section passing through the wall.

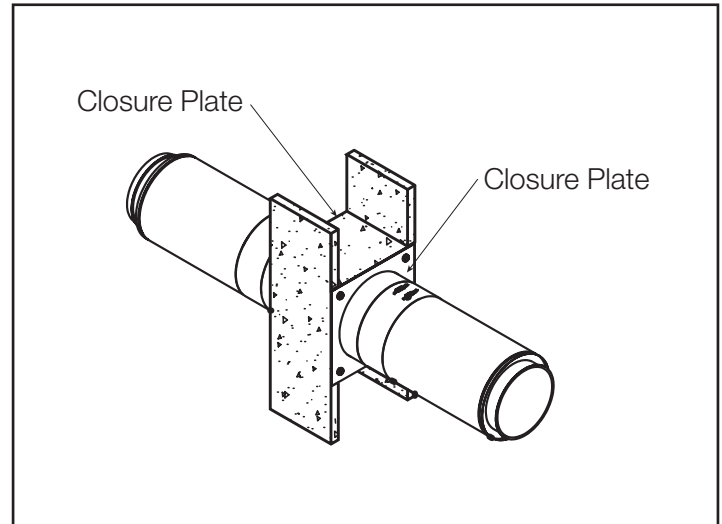

Fig 8-5: Wall Firestop

#### 8.4 FLASHINGS AND STORM COLLARS

Flat Flashings and Adjustable Flashings ( $5^{\circ}$ - $30^{\circ}$ / $32^{\circ}$ - $45^{\circ}$ ) will permit weathering where the chimney passes through the roof structure. The drawing shows a typical application and features the use of the Storm Collar to weatherproof the flashing cone/outer casing interface. Please note that the chimney must be allowed to ride vertically through the cone of the flashing under expansion conditions.

The Storm Collar must be secured and sealed with the provided sealant to the outer casing of the chimney.

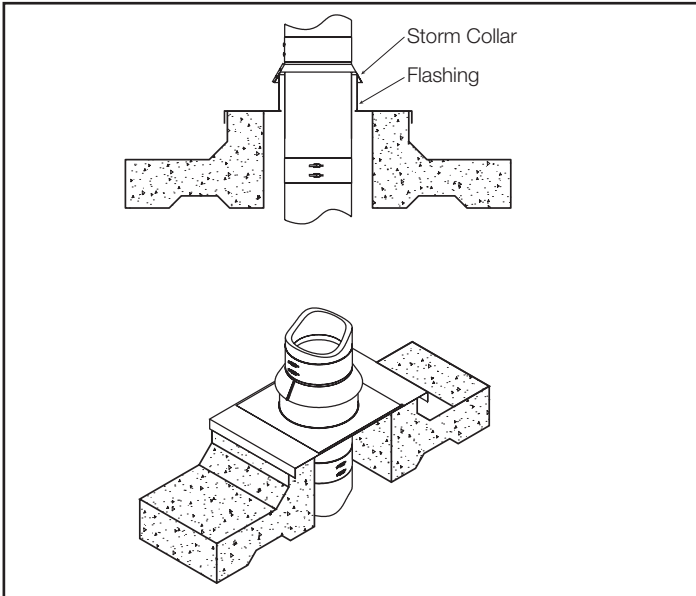

Fig 8-6: Flashings and Storm Collars

Locate as close to the top of the cone of the flashing as possible so that despite expansion, weatherproofing is maintained.

## 9. MISC. COMPONENTS

### 9.1 TRANSITIONS FOR INLINE POWER VENTERS WITH FLANGED CONNECTIONS

The transition is used when connecting an inline power venter with flanged transitions to the EPS. The connection the power venter is customized for the appropriate diameter.

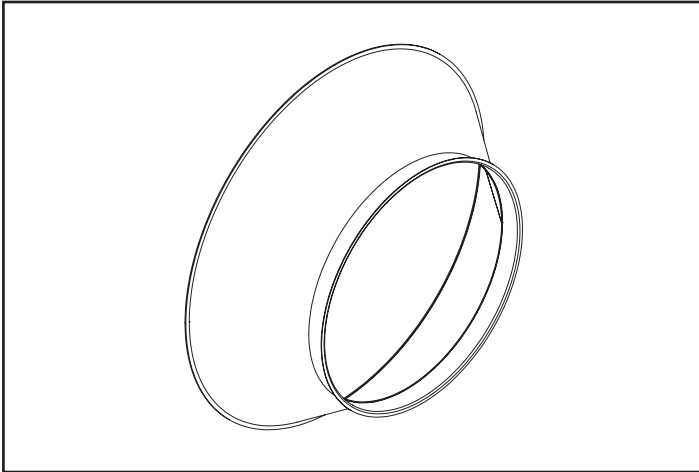

Fig 9-1: Transition with 1/2" Flanged Connections

### 9.2 TRANSITIONS FOR INLINE POWER VENTERS AND ECONOMIZERS WITH BOLT FLANGE CONNECTIONS

The transition is used when connecting an inline power venter or economizer with bolt flange connections to the EPS. The connection the power venter/economizer is customized for the appropriate diameter and bolt pattern.

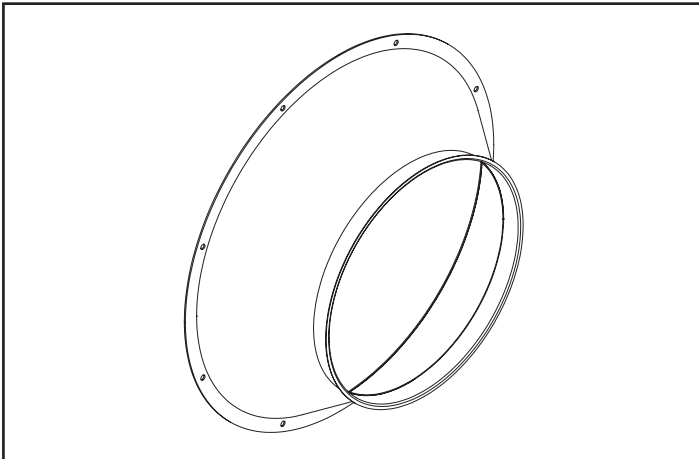

Fig 9-2: Transition w/ Bolt Flange and 1/2" Flange Connection

### 9.3 OTHER TRANSITIONS

ENERVEX supplies other types of custom-made transitions. Shown here is a step-connection from a standard 1/2" flanged chimney to a larger 1/2" flanged chimney or other object.

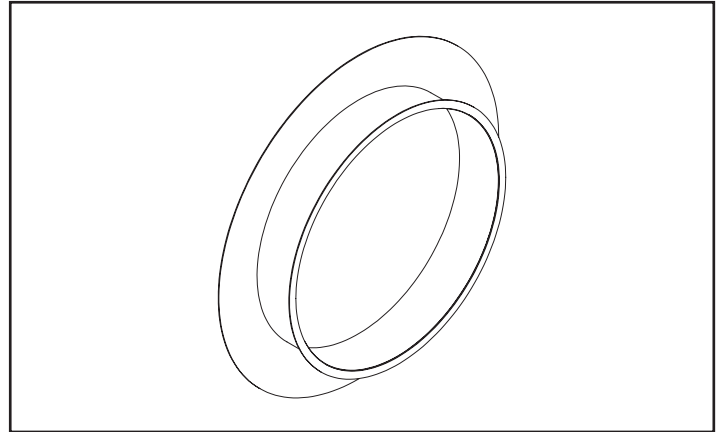

Fig 9-3: Large Step Transition

### 9.4 EXCESSIVE PRESSURE RELIEF VALVE

Excessive Pressure Relief Valves are intended to help control the venting of pressure which may occur during an exhaust system backfire. Engines have the potential to inject unburned fuel into an exhaust system during start up or due to an engine malfunction.

This unburned fuel creates a condition where a backfire could occur. The Excessive Pressure Relief Valve will help prevent damage to other parts such as Flex Connectors, Silencers, Catalytic Converters, Convolved Bellows and Heat Recovery Equipment.

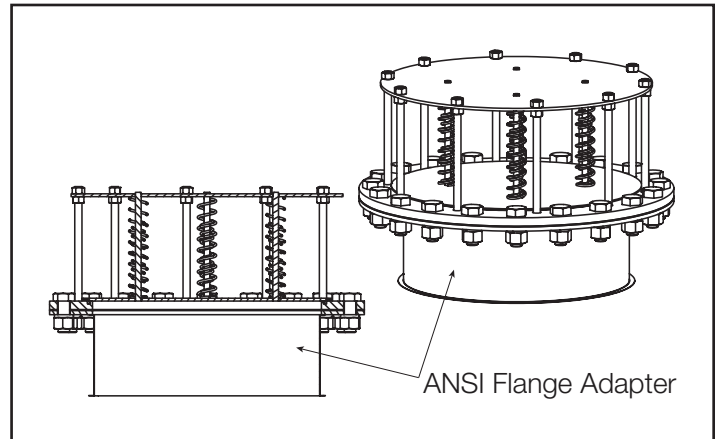

Fig 9-4: Excessive Pressure Relief Valve

#### CAUTION



This device is designed to relieve excessive pressure in the case of an engine malfunction for the sole purpose of protecting the physical integrity of the exhaust system and related parts. If such malfunction occurs, the device will release hot gases, sparks and/or flames into the immediate vicinity of the Excessive Pressure Relief Valve.

---

Further precedence for use of Excessive Pressure Relief Valves can be found in NFPA 37, "Standards for the Installation and Use of Stationary Combustion Engines and Gas Turbines".

The Excessive Pressure Relief Valve should be located in the system at the first change in direction and is supplied with bolts, washers, nuts, and gasket to provide a complete gas tight connection to the 150 lb. ANSI flanged Flange Adapter (see Fig 2.6).

As such, this device should never be installed where human contact with any such release is possible, or near any flammable or combustible materials.

Note: At present (2015), Underwriters Laboratories (UL) has no Safety Standards for these devices, so although they are shown in this document and condoned by ENERVEX and others, UL has not independently investigated this product.

## 10. SAMPLE SYSTEM

### 10.1 CHIMNEY SYSTEM SERVING THREE CONDENSING BOILERS AIDED BY REDUNDANT MECHANICAL DRAFT SYSTEM

ITEM NO.	PART NUMBER	DESCRIPTION	QTY.
1	801.0676.8914	14" SEAL RING	2
2	801.0676.8912	12" SEAL RING	1
3	801.0674.1814	14" EPS1 10" Straight Length	2
4	801.0674.1812	12" EPS1 10" STRAIGHT LENGTH	1
5	801.0674.1414	14" EPS1 20" STRAIGHT LENGTH	4
6	801.0674.2014	14" EPS1 45 DEG TEE	7
7	801.0674.2012	12" EPS1 45 DEG TEE	1
8	801.0674.2414	14" EPS1 45 DEG ELBOW	11
9	801.0674.2412	12" EPS1 45 DEG ELBOW	1
10	801.0674.1914	14" EPS1 90 DEG TEE	2
11	801.0674.1912	12" EPS1 90 DEG TEE	1
12	801.0674.2814	14" EPS1 LONG VARIABLE LENGTH	11
13	801.0674.2812	12" EPS1 Long Variable Length	2
14	801.0674.2620	20" EPS1 LONG ADJUSTABLE LENGTH	2
15	801.0674.1020	20" EPS1 40" STRAIGHT LENGTH	2
16	801.0674.1014	14" EPS1 40" STRAIGHT LENGTH	3
17	801.0674.1214	14" EPS1 30" STRAIGHT LENGTH	1
18	801.0679.1016	16" EPS 40" STRAIGHT LENGTH	14
19	801.0679.1216	16" EPS 30" STRAIGHT LENGTH	1
20	801.0674.1614.20	14" x 20" EPS1 Increaser	4
21	801.0679.3416	16" EPS VENT CAP	1
22	801.0674.3612	12" EPS1 Drain Tee Cap	1
23	801.0674.3614	14" EPS1 Drain Tee Cap	2
24	801.0674.7414	14" EPS1 Tee Cap	1
25	801.0679.3616	16" EPS Drain Tee Cap	1
26	801.0679.2416	16" EPS 45 DEG ELBOW	1
27	801.0679.2016	16" EPS 45 Deg Tee	1
28	801.0677.7516	16" ID FULL RING	4
29	801.0677.7616	16" ID Half Ring	2
30	801.0677.7622	22" ID Half Ring	2
31	801.0712.3416	16" ID STORM COLLAR	2
32	EXH0205	IPVB 500, 230-460/3/60, 3HP	2
33	EXH2703	12" MOTORIZED VENT DAMPER, ADF	1
34	EXH2704	14" MOTORIZED VENT DAMPER, ADF	6
35	EXH0423	ABB ACH550, 3HP, 400V, 6.9A, 3X400-480V NEMA1 (NOT SHOWN)	2
36	PRT2000	Motor Disconnect Switch, NEMA 4X Enclosure (NOT SHOWN)	2
37	EXH0073	EBC30 Modulating Draft Control w/ Probe (NOT SHOWN)	1
38	801.1677.8314	14" EPS1 SUPPORT PLATE	10
39	801.0690.2912	12" BAROMETRIC DAMPER	3
40	801.0677.8334	34" EPS Support Plate	1

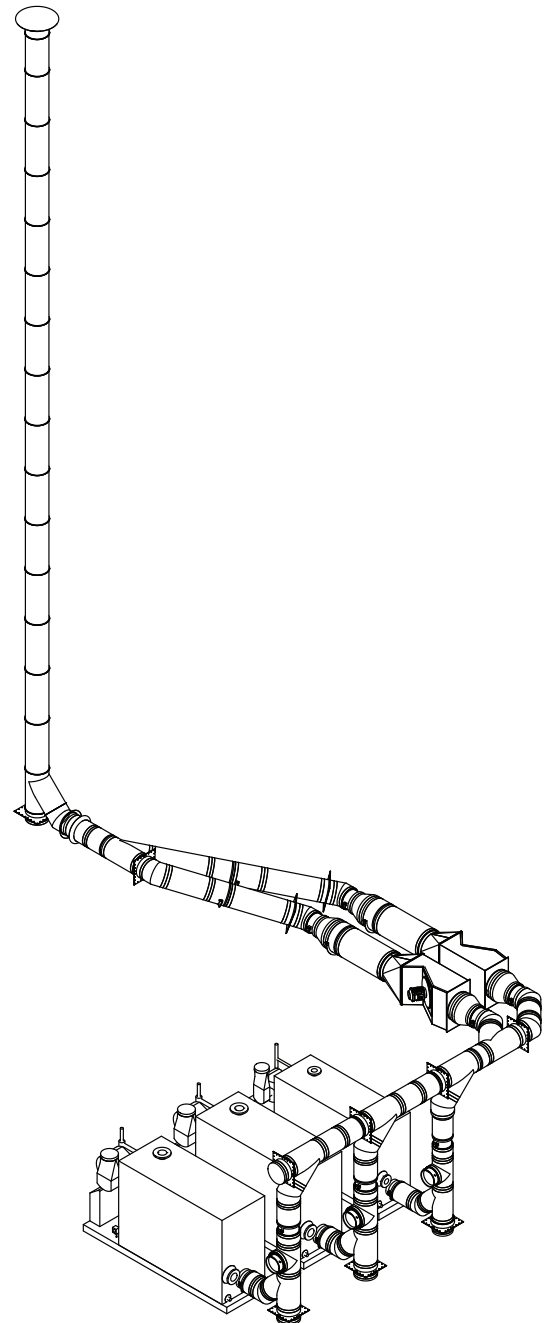

## 11. GREASE DUCT

### 11.1 APPLICATIONS

PowerStack factory built grease duct systems are suitable for use in the removal of smoke and grease-laden vapors from commercial, industrial, institutional and similar type applications. The products are intended for use as complete systems. They connect the hood or grease extractor system to the outdoors through an exhaustor or blower system.

Round PowerStack Grease Ducts provide for efficient airflow (lower friction loss compared to rectangular or square ducting) and superior structural integrity achieved using lighter gauge stainless steel material and fewer reinforcing members. These systems are completely integrated for a very efficient mechanical design and have the additional benefit of providing a very clean appearance on final assembly.

System installation specifications are as described in the NFPA96 and these grease ducts are to be installed to conform to that standard and as described in these installation instructions.

In Canada, applicable codes may vary. Check with local authority for applicable requirements.

(Grease duct systems are not to be interconnected with any other building ventilating or exhaust system.) Systems installed in accordance with these instructions comply with NFPA96, the International Mechanical Code (IMC), Uniform Mechanical Code (UMC) and other codes.

### 11.2 LISTINGS

PowerStack models EPS, EPS1, EPS2 and EPS4 are listed by Underwriters Laboratories in accordance with UL1978, Standard for Grease Duct and ULC S662 Standard for Factory-Built Grease Ducts. Under this category, model EPS has been determined suitable for use in installations using exhaust system components for the removal of smoke and grease-laden vapors from commercial, industrial, institutional and similar type applications. They are intended for use as complete systems. They connect to the hood or grease extractor system to the outdoors through an exhaustor or blower system.

### 11.3 CONFIGURATIONS

PowerStack models EPS, EPS1, EPS2 and EPS4 are based on the same construction. Models EPS is a single wall system composed of the inner liner of Models EPS1, EPS2, and EPS4. Model EPS1, EPS2 and EPS4 incorporate a 1", 2" and 4" fiber insulation between walls, respectively. Component assembly is basically the same for each system.

### 11.4 INTERMIXING OF SYSTEM PARTS

Model EPS, EPS1, EPS2 and EPS4 may be intermixed within a system, assuming proper clearances are maintained for the respective components. When penetrating a roof, only double wall duct sections and appropriate roof penetration components must be used. Do not use single wall model EPS sections to penetrate the roof.

### 11.5 SURROUNDINGS

PowerStack Models EPS, EPS1, EPS2 and EPS4 are primarily intended to be used in noncombustible surroundings.

Where the ducting is installed in an open room and does not require an enclosure it must have a minimum clearance to adjacent combustible walls as shown in Section 11.6 titled "Clearances". The ducting may be located in corners formed by two combustible walls under the above condition.

Interior installations in all buildings should be installed as follows:

1. If a ceiling or wall has a fire resistance rating and is penetrated by a model EPS, EPS1, EPS2 or EPS4 Grease Duct, then the duct shall be enclosed with a continuous enclosure extending from the penetration, through any concealed spaces, to or through the roof so as to maintain the integrity of the fire separations required by the applicable building code.
2. If a ceiling or wall does not have a fire resistance rating and is penetrated by a model EPS, EPS1, EPS2 or EPS4 Grease Duct installed at the correct minimum clearance for unenclosed duct, then no enclosure is required.
3. Where the Model EPS, EPS1, EPS2 or EPS4 ducting extends through any story of a building above that in which the connected appliances are located, it must be enclosed in the upper stories with walls having a fire resistance rating of not less than one hour for buildings of two or three stories in height.

If the building is four stories or more in height, the enclosure wall shall have a fire resistance rating of not less than two hours.

### 11.6 CLEARANCES

When installing the PowerStack grease duct the following clearances must be observed:

Min. Airspace Clearance-to-Combustible for Grease Duct				
Pipe ID	EPS	EPS1	EPS2	EPS4
5"	18" or Per Local Codes. For single wall construction per NFPA 96	4"	2"	0"
6"		4"	2"	0"
7"		4"	2"	0"
8"		4"	2"	0"
10"		5"	3"	0"
12"		5"	3"	0"
14"		5"	3"	0"
16"		5"	3"	1"
18"		5"	3"	1"
20"		5"	3"	1"
22"		5"	3"	1"
24"		5"	3"	1"

Table 11-1: EPS clearance to combustible

For noncombustible construction maintain clearances as required for installation, access for inspection, or per local code.

Combustible roofs may be penetrated by using either the Unvented Insulated Roof Assembly, Fan Adapter and Ventilated Roof Curb or Fan Adapter Termination. Vertical walls or combustible materials may be penetrated using the Insulated Wall Firestop. These are the only parts intended for use with combustible construction. All other parts, such as Plate and Wall Supports, Floor and Wall Guides, are for attachment to noncombustible construction.

### 11.7 SLOPES

Nationally recognized codes require horizontal duct to slope at a minimum of 1/4" per foot towards a grease reservoir or the kitchen hood. In addition, where horizontal ducts exceed 75 feet in length, the slope shall not be less than 1" vertical per foot horizontal. This general rule for duct slope is prescribed for grease ducts that are not listed and/or evaluated by an accredited third body testing agency. For factory-built grease ducts that are listed to UL1978 and have been further tested and/or analyzed to provide equivalent or better flow characteristics as compared to field-installed grease ducts, reduced duct slope is allowed per the factory-built grease duct listing.

For PowerStack factory built grease ducts listed to UL1978, install at a duct slope not less than 1/16" vertical slope per foot of horizontal toward the hood or toward the grease reservoir. Where PowerStack grease ducts listed to UL1978 exceed 75 feet in length, the slope shall not be less than 1/4" vertical slope per foot horizontal. This minimum slope is a result of analysis performed by Underwriters Laboratories, where factory-built grease duct was compared to rectangular field-applied grease duct for performance of flow characteristics.

Consult with AHJ for acceptance of this alternate method. If a specific slope is required, ENERVEX offers various options such as 87° elbows and Tees.

### 11.8 PIPE AND FITTING JOINT ASSEMBLY

All grease ducts must be liquid tight according to NFPA 96. Follow the procedure in Section 1.15 Pipe Joint Assembly to assure that all joints in the installation meet that requirement.

**NOTE: DO NOT SEAL THE CLEANOUT ACCESS COVERS. THEY MUST REMAIN FREE OF SEALANT FOR FREQUENT INSPECTION PURPOSES.**

#### CAUTIONS

1. The outer channel bands are designed to slide in their mating grooves. Do not attach by screws into the outer casing.
2. Do not allow screws to penetrate the inner pipe. This can cause corrosion, grease leakage or expansion failure.
3. Never use screws through the outer jacket of an adjustable length or expansion joint.

### 11.9 MAINTENANCE AND SAFETY

The PowerStack Grease Duct Systems have a special group of parts which are specifically designed to create a safe and reliable system. Those special parts include:

Nozzle/Port Section (special part code) to integrate a fire suppression system or act as an interface for hot water/detergent maintenance system.

Grease Tee's - Provides access to the duct at 90° changes of direction for cleaning and inspection. Includes a 1" required dam to prevent liquids from spilling out when opened.

Cleanout Doors – Allow for access to the snout of a tee for inspecting and cleaning the duct.

Grease Access Cap.

Inline Access Door – Provides access to a straight length of grease duct for cleaning or inspection.

NFPA96 contains some very specific requirements concerning the safety features which must be incorporated into grease duct systems. This document includes guidelines to be followed related to the operation, inspection and cleaning of grease ducts and it indicates that the system shall be cleaned at frequent intervals prior to surfaces becoming heavily contaminated with grease or oily sludge. Depending on the amount of cooking equipment usage there should be a daily or weekly inspection to determine if grease or other residue has been deposited within the section. When the grease or other residues are in evidence as deposits, the entire system should be cleaned in accordance with accepted procedures. The Cleanouts and Access Components (mentioned above) are specifically designed to aid in this process and should be located at each change in direction. Long straight vertical and horizontal runs may require additional cleanouts to allow the system to be completely inspected and cleaned. Spacing requirements for access vary among codes so check the applicable code.

### 11.10 ACCESS FOR CLEANING GREASE DUCTS

Follow NFPA 96 (or other code if applicable) for required openings in the grease duct for accessibility required for thorough cleaning. Some of these openings requirements are:

Openings at changes of direction, if not accessible from the duct entry or discharge.

Access panel openings for installation and servicing of fire-extinguishing systems.

Access for cleaning and inspection where fans with duct work connected on both sides within 3' of each side of fan.

Horizontal grease ducts only:

Opening for thorough cleaning at 12' intervals, where opening is not large enough for personnel entry.

Vertical grease ducts only:

Access at the top of a vertical riser to accommodate personnel descent.



Where personnel entry is not possible, access at every floor.

PowerStack Grease Ducts have two standard options for access panels. These are specifically tested and Listed for Grease Duct use.

Inline Access Door, see Fig 11-3

Grease Duct Tee Cap Access, see Fig 11-2

### 11.11 AUTOMATIC CLEANING

An automatic hot water/detergent injection system can be integrated into the PowerStack Grease Duct systems by using the dual purpose Nozzle/Port Section (which is also used for fire suppression) and Tees with nipped Base Drains. All of these related parts have standard NPT hardware so that conventional nozzles and piping can easily be attached. Please keep in mind that if plumbing is connected to cleanout inspection caps, flexible high temperature, high pressure plumbing must be provided with shutoff valves so that the inspection process can be completed on a regular basis.

A typical installation would provide hot water at approximately 160°F and use a detergent injected by conventional hardware so that the entire grease duct system can be scrubbed down daily (using jet spray characteristics) for the removal of grease, dirt and dust. Normally the automatic cleaning system is designed as a unit, however a modular design would prove satisfactory.

Automatic cleaning implies that the grease drains are connected to appropriate hardware so that the residues of the cleaning process are piped directly to drains and not grease traps or fixed size buckets.

### 11.12 FIRE SUPPRESSION

The practice of NFPA 96 concerning fire safety requires that fire extinguishing equipment shall be provided for the protection of duct systems, grease removal devices and hoods, especially if all the cooking equipment is not served by Listed grease extractors. The use of a special Pipe Section w/Port/Nozzle allows various types of fire extinguishing equipment to be integrated into the grease duct work, if necessary. Some of the various types are:

- CO2 extinguishing systems (NFPA 12),
- Sprinkler systems (NFPA 13),
- Foam-Water Sprinkler/Spray Systems (NFPA 16)
- Dry Chemical Extinguishing Systems (NFPA 17)

The Nozzle Section (See Fig 3-2) can be positioned so that the nozzle fitting is either on the sides or top of the section consistent with good fire protection design practice. Various diameter NPT couplings offered allow for flexibility when making the required connections (See Section 3.2).

Nozzle Grease duct tee sections with sprinkler port are also available for installations requiring sprinkler heads with access for inspection / cleaning. The sprinkler port includes a coupling to accept standard ½" (or ¾") NPT sprinkler heads (See Fig 11-1).

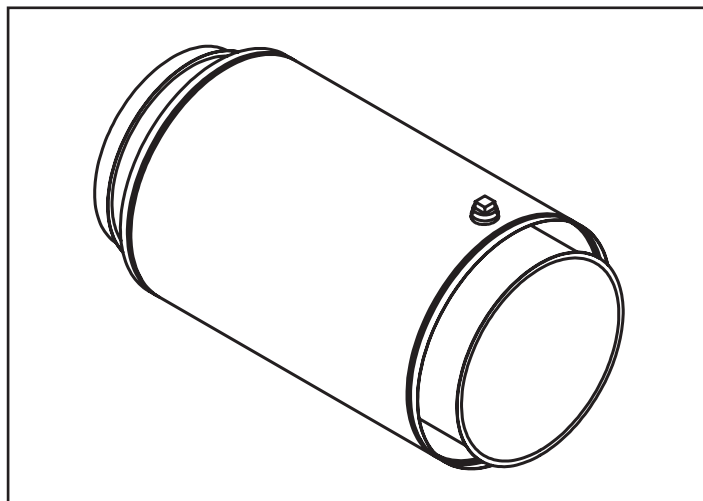

Fig 11-1: Sprinkler Section

### 11.13 INTERCONNECTION WITH RECTANGULAR GREASE DUCTS

As a general rule, PowerStack grease duct systems are intended to be installed as complete systems without the use of other manufactured or generic components. However, ENERVEX recognizes the occasional need for a rectangular portion of the grease duct due to space limitations at certain locations within the system. In such case, it is permissible to transition to/from the PowerStack grease duct to a code compliant, rectangular, welded steel grease duct system (by others) and back again. When such situations occur, ENERVEX will fabricate and supply single wall stainless steel (with code specified 0.043" minimum thickness) round to rectangular transition(s) of the correct dimensions and specifications to permit connection via fully welded (per code) attachment between the PowerStack stainless steel transition(s) and the rectangular grease duct segment(s). (The round end of the transition will mate with the PowerStack round grease duct without welding.)

Maintain proper minimum airspace clearances between any single wall rectangular duct and rectangular/round transitions and combustibles per applicable code. In most cases this minimum airspace clearance will be 18". NFPA 96 specifies approved methods for reducing clearances to combustibles for these single wall ducts and transitions.

Where required by code, these transitions (and the rectangular portion of the system) are to be protected with a fire rated enclosure. Such enclosure may be either a field applied wrap system or separate fire protective shaft enclosure with an appropriate fire resistance rating.

### 11.14 GREASE TEE ACCESS CAP

The Grease Tee Access Cap provides access to the grease duct for inspection and/or cleaning. It can be placed at the end of a Tee. It incorporates a dam to prevent liquid or grease from leaking out when opening.

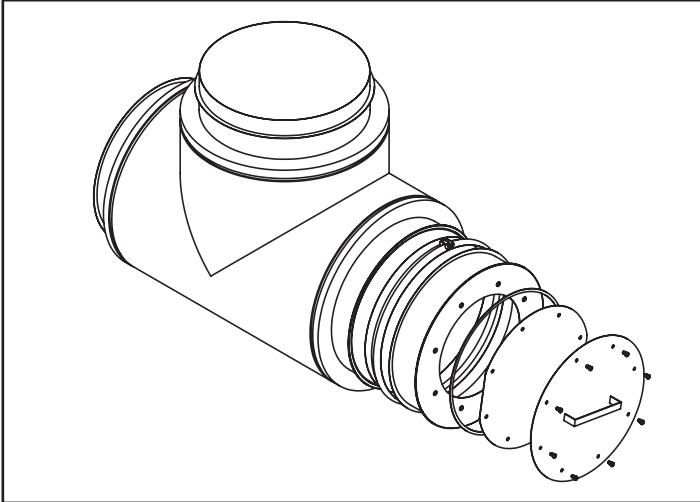

Fig 11-2: Grease Tee Access Cap

### 11.15 INLINE ACCESS DOOR

The Inline Access Door is used for duct inspection and cleaning.

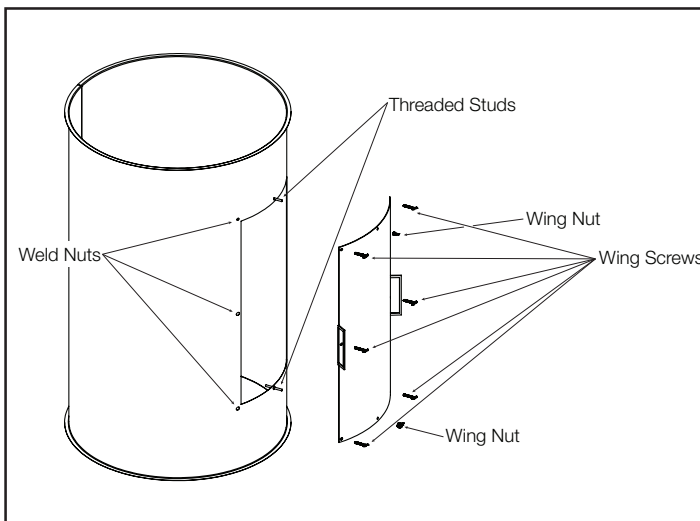

Fig 11-3: Inline Access Door

This part uses a UL listed Flame Gard Curved Access Door. The door is listed to UL1738 under File No. MH19744.

The curved grease duct access door frame is affixed to the inside duct wall. Predrilled holes accommodate the two studs in the center of radius and align with the frame's six weld nuts.

To remove the access panel loosen the two wing nuts and the six wing screws. Pull off the access panel.

To install the access panel, make sure the permanently attached gasket is in a good condition. Place the center holes over the studs in center of radius. Secure with the two wing nuts and the secure with the six wing screws.

If prior to installation, you removed reduced clearance wrap from the surface, you'll need to cover the access panel. To do this, employ two layers of the same material used for the reduced clearance insulation and follow the directions provided for insulating access cover plate. You will need additional hardware to attach the insulation blankets during this step (not provided).

If the access panel is installed in the inner duct of a double-wall insulated grease duct, cover it with the supplied pre-cut insulation mat. Then attach the blanking cover to the outer pipe wall.

**11.16 SAMPLE SYSTEM - GSV FAN**

Lorere sequam quisci officii tecte parum labo. Nam unt quidige ndaeporro te odi offic tem venissita corepratur sequam quam autemprore praecomititiamtia aliantest, aut plitenititlat in porum ereseque dendae volupta quo que pelluptaquia doluptatur anis aliqui apidicimaio et volorestibus alia commimus.

**For Placement Only**

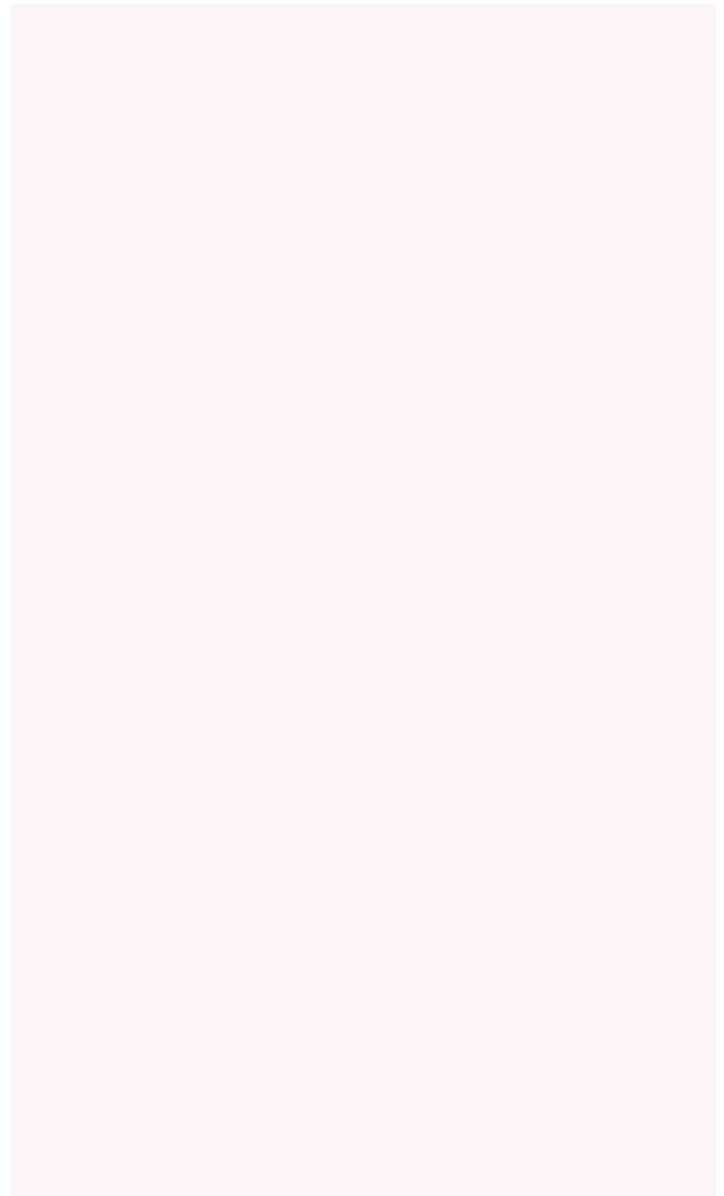

Fig 11-4: Typical Pizza Oven System using GSV Fan

## 12. POSITIVE PRESSURE VENTING SYSTEM LINER AND BREECHING SYSTEM

### 12.1 GENERAL INSTALLATION GUIDELINES

Before beginning any installation of the PowerStack Model EPS chimney liner system, contact code inspection authority (Gas Inspection Authority, Municipal Building Department, Fire Department, etc.) to determine the need to obtain a permit for the installation.

1. These instructions should be observed when installing Model EPS Chimney Liner. Never substitute liner material. The safe operation of the Model EPS lining system is based upon the use of parts supplied by ENERVEX. The use or substitution of parts other than those supplied by ENERVEX for use with Model EPS is not recommended, as they could affect the safety and performance of the system.
2. Failure to install this product in accordance with these installation instructions may result in an installation that the local inspection authority will not accept, could void the warranty and could result in an unsafe installation.
3. Before installing Model EPS, the masonry chimney should be thoroughly inspected for any damage such as cracks, void areas, missing bricks or mortar and other defects. Damaged areas should be repaired prior to installation. Care should also be taken to ensure that the masonry chimney is clean and free from any buildup of creosote. Consult a certified Chimney Sweep if necessary.
4. Installed in an existing masonry chimney under the terms of the CAN/ ULC-S635 Listing and in masonry chimneys under the terms of the UL1777 Listing, Model EPS liner requires only sufficient space within the chimney to accommodate the installation. The minimum internal dimensions necessary for installation will be the liner inside diameter plus approximately 2", to allow for the V-Bands that connect the individual lengths together. (Example: A 16" Model EPS liner will require an approximate 18" minimum inside opening within an existing chimney.)
5. If Model EPS is to be used to line an existing factory-built chimney or vent, such chimney or vent must be thoroughly cleaned and checked for structural defects. Such chimney or vent should also be checked to insure that all parts (supports, radiation shields, firestops, etc.) specified by the chimney or vent manufacturer are installed and that the air space clearances between the chimney or vent exterior casing and combustible material is in accordance with the installation instructions.
6. Correct liner size is important for proper venting. Correct sizing is also particularly important when venting appliances with low flue gas temperatures in geographical areas that experience sustained low ambient temperature because they may be susceptible to icing or blockage at the outlet and associated equipment and personal safety concerns due to improper appliance venting. Unless a specific sizing assessment is conducted and confirms adequate capacity, no portion of the liner should ever be smaller in diameter than the outlet of the appliance it serves. If there is any question concerning whether Model EPS is appropriate for use with certain equipment, contact ENERVEX Technical Support staff for assistance.
7. Model EPS chimney liner should be sized in a manner to reduce excessive amounts of condensation of moisture and weak draft. These factors are often consequences of an oversized chimney and can lead to a reduced service life for the system attributable to excessive condensation and premature corrosion of the system compared to a properly sized system. Weak draft can lead to operational problems and reduced combustion efficiencies of the appliances.
8. If Model EPS is also used as a connector between the appliance and the masonry chimney being lined, treat Model EPS as a single wall connector and follow local code requirements for minimum airspace clearance from combustibles to single wall connectors. See NFPA211 or other code if applicable. If the connector penetrates a combustible wall between the appliance and the inlet to the chimney, follow local code requirements for passing such single wall connector through the wall or use a safety certified "Wall Pass-Through Device" for such purpose.
9. The maximum height from Model EPS will depend upon the diameter of the system being installed and the method of supporting the Model EPS. See Sections 1.17, 1.18 and 1.19.
10. At locations where Model EPS extends above the existing chimney, a flashing or cover plate (may be generic) is recommended to prevent moisture, debris, etc. from entering the area around the liner. The area surrounding the Model EPS within the chimney may include an insulating material only if such insulating material is certified for use with a chimney liner systems or is otherwise acceptable to the local code authority.
11. Model EPS liner should extend a minimum of 1' above the masonry chimney in which it is installed. Follow local code requirements for minimum spacing requirements from chimney terminations to surrounding structures.
12. A Stack Cap or other Model EPS termination cap option is recommended to reduce moisture access to the inside of the flue. Listed rain caps with bird screens or spark arresters are necessary and required in some areas, but may be susceptible to blockage through freezing moisture in areas of low ambient temperature. Consult the authority having jurisdiction for requirements in your area.
13. Portions of Model EPS used as a connector system (between the appliance outlet and the inlet to the Model EPS liner) may be offset virtually horizontal with minimal slope required as per local code.

14. Whereas the UL1777 and CAN/ULC-S635 chimney liner standard contains no specifications for evaluating chimney lining systems for use in positive internal pressure applications, when used as the internal flue liner of Model EPS1, EPS2 and EPS4, Model EPS is safety certified for use in positive internal pressure applications of 15 KPa (60" WC). Therefore Model EPS may be found suitable by the local code authority for use in positive internal pressure applications.
15. Model EPS chimney liner system may be intermixed with Models EPS1, EPS2 and EPS4 chimney system components as part of an "engineered" venting system, assuming the proper associated airspace clearances-to-combustibles, transitions, supports, etc. are used for the various portions of the system. Contact ENERVEX for additional information on combination engineered venting systems incorporating mixed system usage.
16. POSTING OF NOTICES: Upon completion of installation and before the system is put into operation a "Notice" should be posted in the appliance room, near the outlet of the appliance. This "Notice" should contain, as a minimum, the information shown here:

**NOTICE:**

- The chimney liner to which this appliance is attached is Listed per CAN/ULC-S635 as a "Class 3 Lining System" for use in existing masonry or factory-built chimneys and vents. It may be used with oil, gas-fired equipment where the temperature of the flue gas products does not normally exceed 650°C (1200°F).
- The chimney liner to which this appliance is attached is Listed per UL1777 for use with gas fired equipment for flue gas temperatures up to 570°F continuous and short term exposure up to 1700°F.
- Under certain low ambient temperature conditions, some chimney caps can be susceptible to ice buildup. Check cap for ice buildup under such conditions and remove ice if necessary before using the chimney.
- Date of installation: (Fill in) \_\_\_\_\_
- Chimney Liner is Model EPS manufactured by ENERVEX Inc.

**12.2 CONSTRUCTION AND DESIGN**

The PowerStack Model EPS liner system is a rigid single wall venting system made in 316L-PCM stainless steel with fully welded seams. The venting system is designed with the same 1/2" wide flanged male/female joints with integrated graphite gasket as the Model EPS1, EPS2 and EPS4 system.

Model EPS uses many of the same system parts and accessories as the Model EPS1, EPS2 and EPS4 systems. The bespoke 316L-PCM stainless steel ensures maximum oxidation resistance to all types of flue gases and pH levels.

**12.3 LISTINGS**

PowerStack Model EPS is listed by Underwriters Laboratories in accordance with UL1777, Standard for Chimney Liners for use with gas fired appliances with flue gases up to 570°F and short term exposure up to 1700°F.

It is also listed by Underwriters Laboratories in accordance with CAN/ULC-S635, Standard for Lining Systems for Existing Masonry or Factory-Built Chimneys and Vents for use with gas and liquid fuel fired appliances with maximum continuous flue gas temperatures of 650°C (1200°F) of the same system parts and accessories as the Model EPS1, EPS2 and EPS4 systems.

**12.4 INSTALLATION INFORMATION**

The EPS venting system components will slip-fit together. Each component is delivered with a U-band (locking band) which must be installed at all joints to ensure a correct mechanical connection between the components. A positive pressure seal for application up to 60" WC is assured by the integrated graphite gasket.

The EPS venting system is very flexible due to the large range of components available. All horizontal breechings are designed with a minimum 5° slope towards the appliance connector component.

Follow these installation recommendations:

1. When a liner is installed inside a chimney, a centering band should be used at every 10 feet (3m) to ensure proper centering of the liner and for stability. Supports are required at intervals specified in Table 1-7.
2. Top support on top of a chimney may be necessary in order to support the liner. No extra support or braces are required for freestanding installations extending up to 8 feet (2.4m) above the roof line in regions with normal weather conditions. Beyond 8 feet (2.4m) and up to 13 feet (4m) above the roof line, the installation can be stabilized using a Guy Section Assembly.
3. When a vent is installed along a vertical surface, such as a wall, a Wall Guide is required to ensure the stability of the vent. These are not load bearing components. They should be installed at every 13 feet (4m) after any support on outside wall and 12 feet (3.5m) on interior wall.
4. In a horizontal breeching Half rings or Full Rings should be used at every 13 feet (4m) (see Table 1-10) to support the breeching. It must also be used at every change of direction and change of diameters.
5. To facilitate the installation of a horizontal or diagonal venting section, an adjustable length is available. The adjustable length can be cut to fit shorter component but when installed must protrude into the component by a minimum of 3 inches (80 mm).
6. The use of a 95° Tee or a 135° Lateral Tee makes it possible to laterally connect an appliance outlet to a vertical installation.

7. An adaptor is available to connect the system to appliances. The EPS connects to double wall EPS1, EPS2 and EPS4 systems without the use of adapters.
8. When used as a liner and exiting a chimney or when used as a venting system and passing through the roof, a roof flashing for weather protection is required. Several types of roof flashings are available. Each flashing is made from stainless steel and comes complete with a storm collar. To ensure waterproofing, the joint between the storm collar and EPS component must be sealed using a clear silicone.
9. Two types of vent termination caps are available and must be used at the end of each installation.

## 12.5 INSTALLING EPS AS A LINER IN A MASONRY CHIMNEY OR AS A LINER IN AN EXISTING VENT

Note: This section applies to ULC-5635 applications only.

1. Stainless Steel Wire Rope (by others) is to be used to hang the vent system from the top of the masonry chimney or from the top of the existing vent.
2. The stainless wire rope is attached to the Guy Support Band and is secured with cable clamps (by others).
3. The Stainless Steel Wire Rope is secured in a similar manner to the top platform of the masonry chimney or existing vent.
4. Use the appropriate size of Stainless Steel Wire Rope (1/8" min.) to accommodate the required total loads of the vent system. It may be necessary to fabricate a platform (at top of chimney I vent - by others).

DO NOT USE GALVANIZED WIRE ROPE.

Note: When installed as a liner in a masonry chimney or to reline an existing vent no other appliance can be vented into the same chimney or vent.

## 12.6 VENT MAINTENANCE

Performed on a regular scheduled maintenance program. The vent surface can be cleaned by using a solution of water and vinegar. The vent interior should be washed with a hose during the non-heating season as regular maintenance. All drain connections are to be inspected and made free of debris.

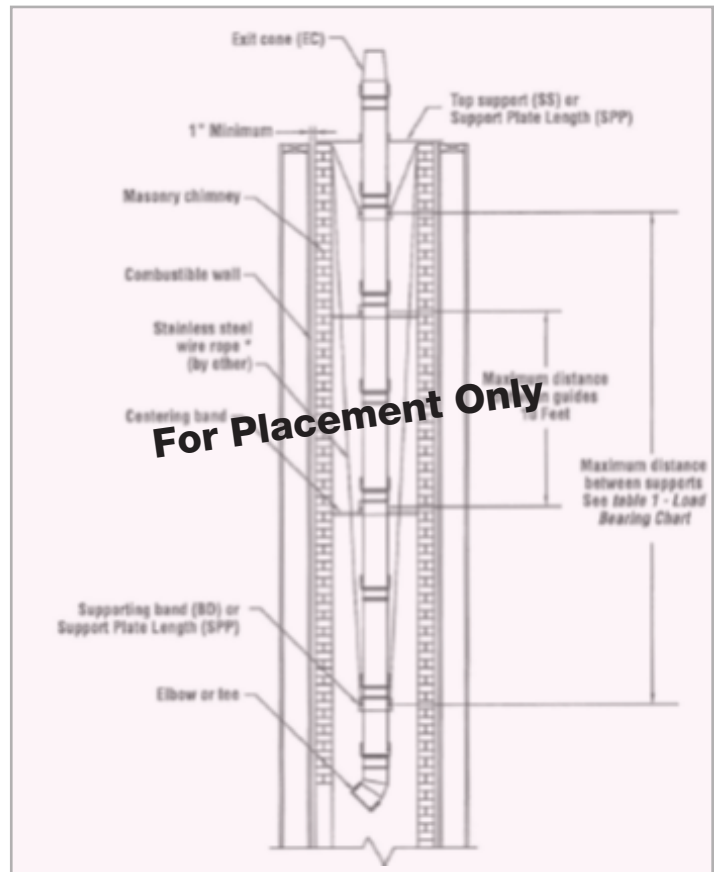

## 13. WARRANTY

### 13.1 STANDARD 1-YEAR WARRANTY

ENERVEX Inc. ("ENERVEX") warrants the chimney and engine exhaust system and components against functional failure due to defects in material and workmanship for a period of one year from date of delivery to the construction site. Functional failure is defined as any failure of the system or component to perform its intended function of exhausting, without adverse leakage, combustion by-products from engine operation or heating equipment. During this period, any system or component supplied by ENERVEX failing to perform its intended function will be repaired or replaced at the manufacturer's option, following determination by a factory-authorized inspector that a functional failure has occurred. This warranty is limited to repair or replacement of the product plus shipping cost to the failure location. This warranty does not cover any labor costs for removal or replacement of the defective product, nor does this warranty cover any system components not furnished by ENERVEX and installed as part of the system.

This limited warranty is extended to the purchaser subject to the satisfaction of the following conditions:

- 1) Generally accepted engineering practices have been followed to determine that sizing and material specifications are suitable for the application and environment involved.
- 2) The undamaged components have been correctly installed in accordance with the installation instructions published by ENERVEX at the time of shipment.
- 3) Damage is not a result of burning garbage, waste oil, #6 oil or any other prohibitive material in the appliance served by the venting system.

### 13.2 EXTENDED 15-YEAR WARRANTY

This limited warranty is extended to the purchaser for fifteen years, subject to the satisfaction of the following conditions:

- 1) System sizing and design has been performed by ENERVEX personnel, and design parameters provided to ENERVEX by the responsible engineer were and are accurately representative of the operating conditions.
- 2) The undamaged components have been correctly installed in accordance with system design and sizing as performed by ENERVEX and installation instructions published by ENERVEX at the time of shipment.
- 3) Proper precautions have been taken to insure that boiler or engine combustion air is free of solvent or refrigerant vapors or any halogenated compound which may cause acid condensates to form within the chimney.
- 4) Damage is not a result of burning garbage, waste oil, #6 oil or any other prohibitive material in the appliance served by the venting system.
- 5) ENERVEX has supplied the entire chimney or exhaust system from boiler/engine outlet to the termination of the stack. The ENERVEX 15&1 Warranty applies to the following products: EPS, EPS1, EPS2 and EPS4 used in Commercial/Industrial/Institutional applications.

#### Disclaimer:

ENERVEX assumes no liability for incidental or consequential damages of any kind or for any damages resulting in whole or in part from misuse, improper installation, or inadequate maintenance of the system or any component part thereof.

This warranty is in lieu of all other express warranties or guarantees of any kind. All implied warranties, including merchantability and fitness, are limited to the duration of the express warranty contained herein. ENERVEX neither assumes nor does it authorize any other person to assume on its behalf any other liability in connection with the sale of its products.

ANY IMPLIED WARRANTY OF MERCHANTABILITY OR FITNESS FOR A PARTICULAR PURPOSE IS LIMITED IN DURATION TO THE WARRANTY PERIOD SPECIFIED ABOVE. WE DISCLAIM ANY LIABILITY FOR CONSEQUENTIAL OR INCIDENTAL DAMAGES AND ANY LOSS OR EXPENSES(S), NOT SPECIFIED ABOVE. SOME STATES MAY NOT ALLOW THE EXCLUSION OR LIMITATION OF INCIDENTAL OR CONSEQUENTIAL DAMAGES, OR HOW LONG AN IMPLIED WARRANTY LASTS, SO THE ABOVE EXCLUSIONS OR LIMITATIONS MAY NOT APPLY TO YOU. THIS WARRANTY GIVES YOU SPECIFIC LEGAL RIGHTS AND YOU MAY ALSO HAVE LEGAL RIGHTS WHICH VARY FROM STATE TO STATE OR PROVINCE TO PROVINCE.

ENERVEX Inc.  
1685 Bluegrass Lakes  
Parkway  
Alpharetta, GA 30004  
USA

P: 770.587.3238  
F: 770.587.4731  
T: 800.255.2923  
info@enervex.com  
www.enervex.com

**ENERVEX®**   
VENTING DESIGN SOLUTIONS