





GSV 009-016 grease fan



READ AND SAVE THESE INSTRUCTIONS!

	Product information	Chapters 1 + 2
	Mechanical installation	Chapter 3
	Electrical installation	Chapter 4
	Start up and configuration	Chapter 5
	Maintenance and troubleshooting	Chapter 6

USA

CAN

Job name: _____

Installer: _____

Installation date: _____

Distributor contact information:
ENERVEX Inc. • T: 800.255.2923
info@enervex.com • www.enervex.com



Contents

1. Product information	
1.1 Function	4
1.2 Components	4
1.3 Shipping	5
1.4 Warranty	5
2. Specifications	
2.1 Dimensions and capacities	6
3. Mechanical installation	
3.1 Positioning	7
3.2 Installation on steel duct	7
3.3 Installation on roof curb	8
3.4 Installation on side wall	8
3.5 High temperature applications	8
4. Electrical installation	
4.1 Electrical requirements	9
4.2 Wiring diagram	9
5. Start-up and configuration	
5.1 System testing	10
5.2 Testing pizza oven operation	10
5.3 Adjusting fan speed	11
5.4 Operation of pizza ovens	11
6. Maintenance and troubleshooting	
6.1 Care and cleaning	12
6.2 Chimney cleaning intervals	12
6.3 Creosote formation and need for removal	12
6.4 Inspection schedule	12
6.5 Chimney fires and what to do about them	13
6.6 Spare parts ordering	14
6.7 Troubleshooting	15

Symbol legend

The following terms are used throughout this manual to bring attention to the presence of potential hazards or to important information concerning the product.



DANGER

Indicates an imminent hazardous situation which, if not avoided, will result in death, serious injury or substantial property damage.



CAUTION

Indicates an imminent hazardous situation which, if not avoided, may result in personal injury or property damage.



**TO REDUCE THE RISK OF FIRE,
ELECTRICAL SHOCK OR INJURY TO
PERSONS, OBSERVE THE FOLLOWING:**

1. Use this unit in the manner intended by the manufacturer. If you have questions, contact the distributor at the address or telephone number listed at the back of the manual.
2. Before servicing or cleaning the unit, switch off at service panel and lock service panel to prevent power from being switched on accidentally.
3. Installation work and electrical wiring must be done by a qualified person(s) in accordance with applicable codes and standards.
4. Sufficient air is needed for proper combustion and exhausting of gases through the flue (chimney) of the fuel burning equipment to prevent backdrafting. Follow the cooking equipment manufacturer's guidelines and safety standards such as those published by the National Fire Protection Association (NFPA), and the American Society for Heating, Refrigeration and Air Conditioning Engineers (ASHRAE) and the local code authorities.
5. This unit must be grounded.



**TO REDUCE THE RISK OF INJURY TO
PERSONS IN THE EVENT OF A CHIMNEY
FIRE, OBSERVE THE FOLLOWING:**

1. Immediately close all dampers and/or air entrance openings to the cooking appliance. This includes doors.
2. Alert your building inhabitants about possible danger.
3. Inspect your cooking appliance and chimney surroundings for possible fire. If in doubt, alert your fire department.
4. Do not continue to use your appliance until it and your chimney have been thoroughly inspected. Overheating can cause metal parts to expand, buckle and crack. If you are not certain, have a certified chimney sweep disassemble all parts so they can be inspected and cleaned.
5. Do not use salt or water on the fire in the cooking appliance. Salt is corrosive and water will cause a dangerous steam explosion. You might be able to control the fire by using ashes, sand or baking soda, since baking soda is an ingredient used for dry chemical fire extinguishers.
6. After a chimney fire, when it is safe to do so, check internal locations such as an attic and under the roof and keep watching for two or three hours. There may be delayed smoldering and subsequent ignition, even if the fire inside the chimney has been controlled.

TO REDUCE THE RISK OF A CHIMNEY FIRE:

1. Keep chimney and grease fan clean.
2. Always turn ON fan when using the cooking appliance.
3. Do not leave cooking appliance unattended when in use.

CAUTION

Please read specification label on product for further information and requirements.



1. Product information

4

1.1 Function

- Use** The **exodraft** model GSV grease fan is designed to provide a large exhaust volume at a high discharge velocity. It is intended for use as a part of a restaurant exhaust system for solid fuel cooking appliances and grease applications according to NFPA96. The use of the grease fan is not restricted to any type of chimney or grease duct. However, always follow the solid fuel appliance manufacturer's instructions regarding the venting. The GSV is suitable for use with natural gas, LP-gas or solid fuel. The fan is designed to create a mechanical draft in chimney and grease duct systems. It can also be used to increase the capacity or efficiency of such a system.
- Construction** The housing is made in heavy cast aluminum and can be opened for easy cleaning. The axial vane is made of stainless steel and is completely in balance. The motor is a direct-drive, variable speed, class H insulated, high temperature motor. It has permanently lubricated and sealed ball bearings and is maintenance free.
- Code compliance** Installation must conform to the requirements of the authority having jurisdiction. Where required by the authority having jurisdiction, the installation must also conform to the NFPA54, NFPA96 or NFPA211. All electrical wiring must be in accordance with the requirements of authority having jurisdiction or, in absence of such requirements, with the National Electrical Code, NFPA70.
- Listings** GSV is tested and listed to UL 705 Standard Supplement SC (Formerly UL 762) for Power Ventilators and UL Standard 762 for Power Ventilators for restaurant exhaust ventilators.
- The model is also tested and listed to ULC-S645-93, Standard for Power Roof Ventilators for Commercial and Institutional Kitchen Exhaust Systems.

1.2 Components

The GSV Grease Fan consists of the following components:

- a. Top section
- b. Bottom section
- c. Motor
- d. Carrying handle
- e. Axial vane
- f. Wiring conduit
- g. Inlet for impeller
- h. Locking hinge
- i. Bird screen

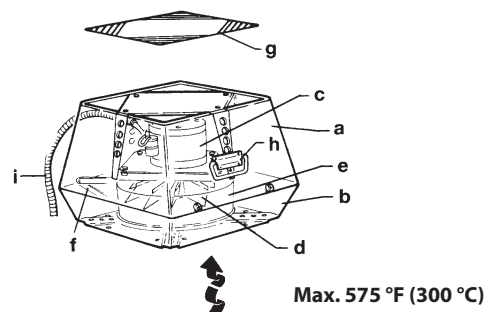

Fig. 1

1.3 Shipping

Transport The fan is shipped in a corrugated cardboard box. If a transport securing device is attached to the bottom of the fan to hold the motor and impeller in place, do not remove the transport securing device before the fan is ready for immediate installation.



Do not remove the transport securing device until the fan is being installed on the duct or the roof curb. The motor shaft could be damaged.

Standard Fan with flexible conduit terminating 2" x 4" or 4" x 4" weather tight junction box.

Packing list If other components are shipped, these will appear on the shipment packing list.

NOTE

All single phase fans are shipped with a capacitor and junction box connected via conduit. The capacitor is located INSIDE the junction box. Please do not discard.

1.4 Warranty

2-Year Factory Warranty

We promise the original user that we will replace or repair as we may elect, any part or parts of the new GSV Chimney Fan which are defective in material or workmanship without charge for parts and labor (not including labor for dismantling and installation, freight, etc.) during the first 2-years following the date of invoice.

10-Year Corrosion Perforation Warranty

We promise the original user that we will replace or repair as we may elect, any part or parts of the GSV Chimney Fan which are perforated due to corrosion without charge for parts or labor (not including dismantling and installation, freight, etc.) during the first 10-years following the date of invoice.

Complete warranty conditions are available at www.enervex.com or request a copy at: info@enervex.com or at tel.: 1-800.255.2923.

2. Specifications

2.1 Dimensions and capacities

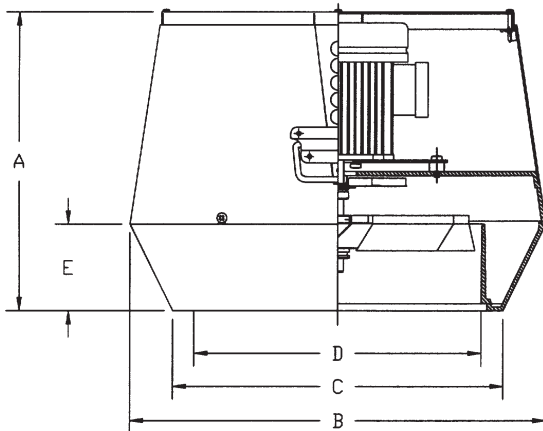

Model		GSV 009	GSV 012	GSV 014	GSV 016	
Discharge		Vertical				
Fan type		Axial Vane				
Max. discharge velocity	FPM	2,351	2,592	2,593	2,169	
Actual discharge velocity	FPM	5.9 x CFM	2.9 x CFM	1.9 x CFM	1.2 x CFM	
Voltage	VAC	1 x 120				
RPM		1600	1600	1600	1580	
Amps	A	0.5	1.4	2.9	5.3	
Motor power	kW	0.025	0.10	0.16	0.35	
Weight	lbs	28	46	60	86	
	kgs	12	18	26	35	
Dimensions	A	in	9.85	11.03	13.20	14.97
		mm	250	280	335	380
	B x B	in	12.21	15.37	19.11	22.85
		mm	310	390	485	580
	C x C	in	9.46	12.22	15.17	18.32
		mm	240	310	385	465
	D Ø	in	8.63	10.72	13.04	14.26
		mm	219	272	331	362
E	in	2.76	3.15	3.94	4.53	
	mm	70	80	100	115	



3. Mechanical installation

3.1 Positioning

Considered a mechanical draft system, there are much different code requirements than for a gravity venting system or grease ducts used with gas or solid fuel applications. As a general rule, the mechanical draft system must be installed min. 3 feet away from any forced air inlet located within 10 feet, and min. 4 feet away from any door or window. For complete information, consult ENERVEX or your local building codes.

-  **Adequate fresh air must be provided for combustion; otherwise, improper operation and inadequate venting of deadly flue gases may result.**
-  **If you are installing the fan on an existing chimney system or grease duct, you must clean the chimney or duct prior to installation.**
-  **Always use a certified chimney sweep, certified by the Chimney Safety Institute of America (CSIA) to clean the chimney, duct and grease fan.**

3.2 Installation on steel duct

- Insert the steel chimney adapter into the chimney where the long collar engagement ensures safe anchoring (see Fig. 2). If necessary, the adapter can be secured by means of long self-tapping stainless steel screws into the side of collar through the chimney wall. Do not obstruct the flow.
- Turn the **exodraft** fan upside-down and lay a bead of hi-temp silicon on the base close to the outer edge (not shown).
- Remove the transport securing device (if present) holding the motor shaft and impeller in place.
- Place the fan on the adapter with the fan inlet centered over the chimney outlet.
- Open the fan and secure the fan onto the adapter, through the pre-drilled holes in the bottom, with lag bolts or self-tapping sheet metal screws, one at each corner.
- Seal around the fan base to make sure it is watertight and no water can slip in between the fan and the adapter. Do not block the 4 drain holes.

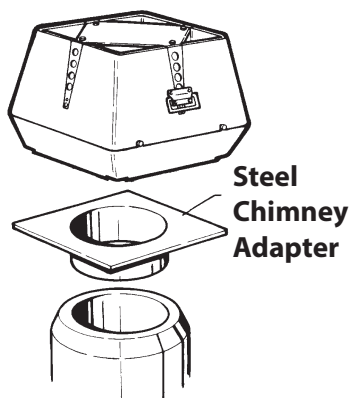
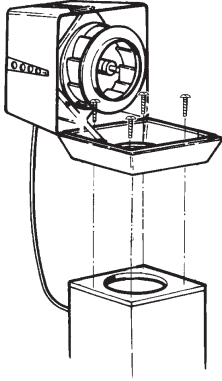

Fig. 2

3.3 Installation on roof curb

8

If the fan is installed on a roof curb, the curb will do the same as the adapter. Follow the instructions under 3.2



3.4 Installation on side wall

- Make sure the vent terminates flush with the wall. Insert the steel chimney adapter and secure it safely to the wall. Seal around the edges of the adapter flange.
- Mark the locations of the wall anchors and predrill holes for them.
- Turn the fan upside-down and lay a bead of hi-temp silicone on the base close to the outer edge (not shown).
- Open the fan and secure the fan onto the adapter with wall anchors, through the pre-drilled holes in the bottom. Make sure the conduit is located on one of the sides. Never on the upside or downside.
- Seal around the fan base to make sure it is watertight and no water can slip in between the fan and the adapter. Do not block the 4 drain holes.

3.5 High temperature applications

- If the fan is used for applications that exceed its temperature rating, dilution bolts must be used.
- Install the dilution bolts in the outer holes of the fan base.
- Adjust the height of the dilution gap by adjusting the dilution bolts, so the temperature of the exhaust going through the fan does not exceed the fan's temperature rating.
- Be aware the dilution bolts will have a negative impact on the fan's actual capacity and a stronger fan model may be required. For more information, please refer to the installation manual accompanying the dilution bolts.

⚡ 4. Electrical installation

4.1 Electrical requirements

Power requirements are dependent on the fan size and can be found on page 6.



DANGER

Turn off electrical power before servicing. Contact with live electric components can cause shock or death.



NOTICE

If any of the original wire supplied with the system must be replaced, use similar wire of the same temperature rating. Otherwise, insulation may melt or degrade, exposing bare wire.

4.2 Wiring diagram

The connection diagram below shows how the **exodraft** fan is connected to the fan speed control and the power source (see Fig. 4).

Use a 2-conductor wire of min. 14 AWG with ground.

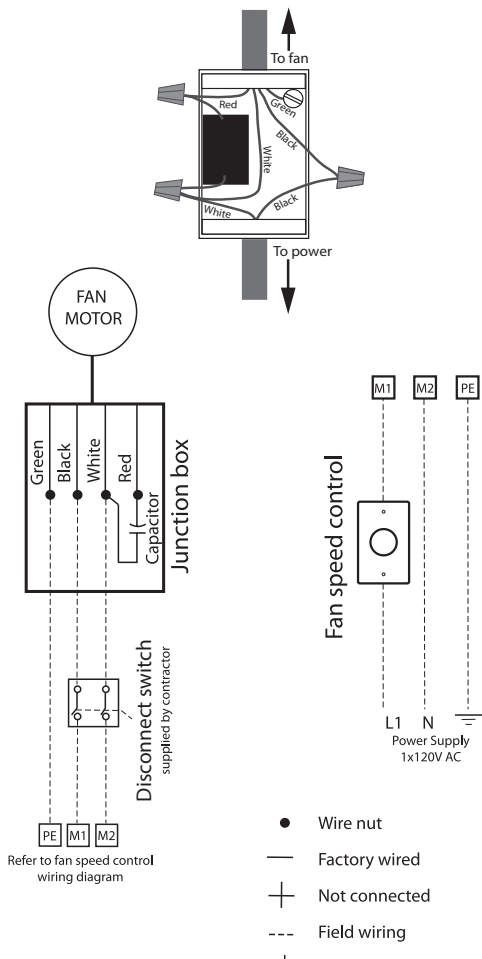

Fig. 4



5. Start-up and configuration

10

5.1 System testing

- Check the line voltage with the motor nameplate rating.
- Determine if the axial vane is running free and has not been subject to misalignment in shipping or installation.
- Turn the **exodraft** grease fan ON and make sure that it is operating. Adjust the fan speed control to make sure it is operating properly.



Prior to using a cooking appliance, make sure that sufficient air needed for proper combustion and exhausting of gases from oil/gas-fired appliances, like water heaters, furnaces and boilers, is provided.

- With the fan ON, check that other heating appliances (furnace, water heater, etc.) are operating safely without spillage (spillage is the escape of flue gases from the relief opening of the draft hood of an atmospheric appliance). On start-up, a little spillage is normal, but it must stop after a couple of minutes.
- Spillage can be detected by introducing smoke into the flue products ahead of the draft hood or by observing if the flame of a match goes out when it is held at the edge of the draft hood relief opening (See Fig. 5).

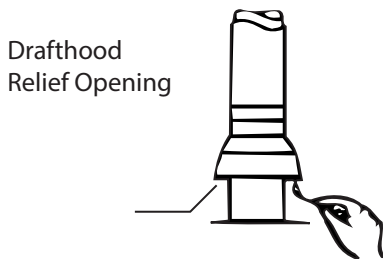

Fig. 5

5.2 Testing pizza oven operation

Most pizza ovens consist of a dome with a front opening that can be closed with a cast iron door. Above the opening, a hood connected to the flue assures smoke and odors are collected and removed safely (see Fig. 6).

Place a few logs in the back of the dome and set the fan at high/full speed. Light the fire. Turn on all exhaust fans (range hoods, etc.) and make sure that there is no spillage from the hood into the room. When the fire has caught on, reduce the speed of the grease fan to a point where it still removes the flue gases safely. Mark this setting on the fan speed control cover, as this will be the operating position/speed of the grease fan.

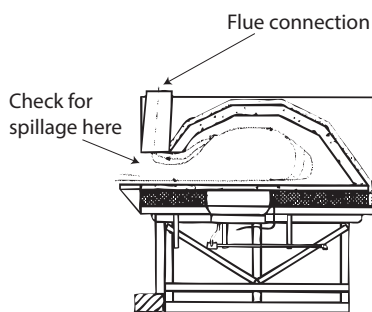

Fig. 6

5.3 Adjusting fan speed

Start all heating appliances connected to the chimney fan installed. Set the fan speed control to the speed where no spillage is experienced anywhere in the system.

5.4 Operation of pizza ovens

Prior to starting a fire, set the fan at high/full speed and start the fire following the oven manufacturer's instructions or, in the absence of such instructions, follow normal instructions on burning a fire in a fireplace or stove.

After the fire catches on, after 3-5 minutes, reduce the speed of the grease fan to a level where it safely removes the flue gases and a perfect flame can be maintained.

When adding wood to the fire, it may be necessary to increase the fan speed for a short period of time.



Do not over-fire the pizza oven. Small deposits of creosote could be ignited and start a small chimney fire which could cause the chimney flue to reach a hazardous temperature.

6. Maintenance and troubleshooting

12

6.1 Care and cleaning

The **exodraft** grease fan is designed for prolonged use. The fan should be inspected at least once a year when the chimney is inspected. Deposits should be removed from the fan blades or the impeller and the bottom of the motor housing. **The run capacitor is considered a wear part and will need to be replaced depending on usage.**

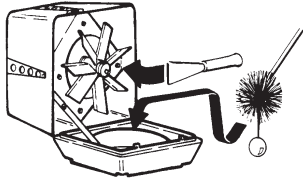

Fig. 7

The top of the fan is hinged and can be opened in order to ease the cleaning.



Do not open the motor housing unless power to the grease fan has been disconnected.

6.2 Chimney cleaning intervals

The need for chimney and chimney fan maintenance depends on how the cooking appliance is operated. Pizza ovens and BBQ's need a great deal of chimney and chimney fan maintenance. These appliances produce dense smoke consisting of creosote and grease if it is loaded for long durations or overnight fires.

6.3 Creosote formation and need for removal

When wood is burned slowly, it produces tar and other organic vapors, which combine with expelled moisture to form creosote. The creosote vapors condense in the relatively cool chimney flue of a slow-burning fire. As a result, creosote residue accumulates on the flue lining. When ignited, this creosote makes an extremely hot fire.

Creosote causes many problems. Some are visible, while others are not. It can make trouble if:

- It runs down outside the pipe to damage the finish on the metal.
- It drips out of joints, damaging floors or furnishings.
- It plugs up the chimney causing poor combustion, smoking, soiling walls and indoor pollution.
- It catches fire in the chimney to cause possible chimney damage and damage to the building.

6.4 Inspection schedule

The chimney and the chimney fan should be inspected at least every 2 weeks for the first couple of months to determine at what rate the creosote builds up. If creosote has accumulated, it should be removed to reduce the risk of a chimney fire.



Evaluation of chimney systems installed in commercial restaurants serving a wood-fired cooking appliance indicates a build-up of 1/8-1/4" of creosote for every 4 cords of wood burned. This can be used as a guideline, but each application is different.

As a guideline, a chimney and grease fan serving a commercial wood-fired cooking appliance should be cleaned at least once a month, unless the use has proven this to be more than adequate.

Most chimney manufacturers require, if you see deposits more than 1/16" thick, clean all chimney parts mechanically. This means using brushes, scraping or equivalent.

**Do not start a chimney fire as a means to clean the chimney!**

With only slight deposits, try a hot fire to see if the black deposits fall down the chimney. You can hear the sound of falling deposits when the temperature conditions are right. Afterwards, reinspect the chimney and the inside of the oven for deposits.

**Do not use chemical cleaners, they may corrode the inside of the chimney.**

They may or may not prevent or remove the creosote. When they are used together with a hot fire, it is probably the fire that is doing the work.

Depending on the rate of build-up, as you learn what is going on in the chimney, you can adjust your cleaning schedule.

If you have doubts about your ability to clean the chimney, or if the deposits are very heavy and hard to remove, do not try to burn them off. Call a professional, certified chimney sweep. The National Chimney Sweep Guild can refer you to the nearest certified chimney sweep. The Guild's phone number is (301) 963-5600.

It does not matter how careful you are loading fuel, selecting wood or controlling draft, you should always observe the above precautions with any solid-fuel burning cooking appliance.

6.5 Chimney fires and what to do about them

No chimney or chimney fan is intended or designed for use as a combustion or fire chamber. It is very easy to overfire a wood burning oven with kindling, scrap, lumber, brush or any fast burning fuel. This can produce flames and high temperatures all the way up the chimney and may cause chimney fan damage.

The creosote may be burning inside the chimney. If you can see flames coming out of the top, you are either over firing or there is a chimney fire.

If the fire in your cooking appliance/chimney has gotten out of control, or if you suspect a chimney fire for any reason, follow these steps:

1. Immediately close all dampers and/or air entrance openings to the cooking appliance. This includes doors.
2. Alert your patrons to the possible dangers.
3. Inspect your cooking appliance and chimney surroundings for possible fire. If in doubt, alert your fire department.
4. Do not continue to use your cooking appliance until it and your grease fan have been thoroughly inspected. Overheating can cause metal parts to expand, buckle and crack. If you are not certain, have a certified chimney professional disassemble all parts so they can be inspected and replaced, if necessary.
5. Do not use salt or water on the fire in the cooking appliance. Salt is corrosive and water will cause a dangerous steam explosion. You might be able to control the fire by using ashes, sand or baking soda, since baking soda is an ingredient used for dry chemical fire extinguishers.
6. After a chimney fire, when it is safe to do so, check internal locations such as an attic and under the roof and keep watching for two or three hours. There may be delayed smoldering and subsequent ignition, even if the fire inside the chimney has been controlled.

6.6 Spare parts ordering

14

When ordering spare parts please have the model number and part position number available.

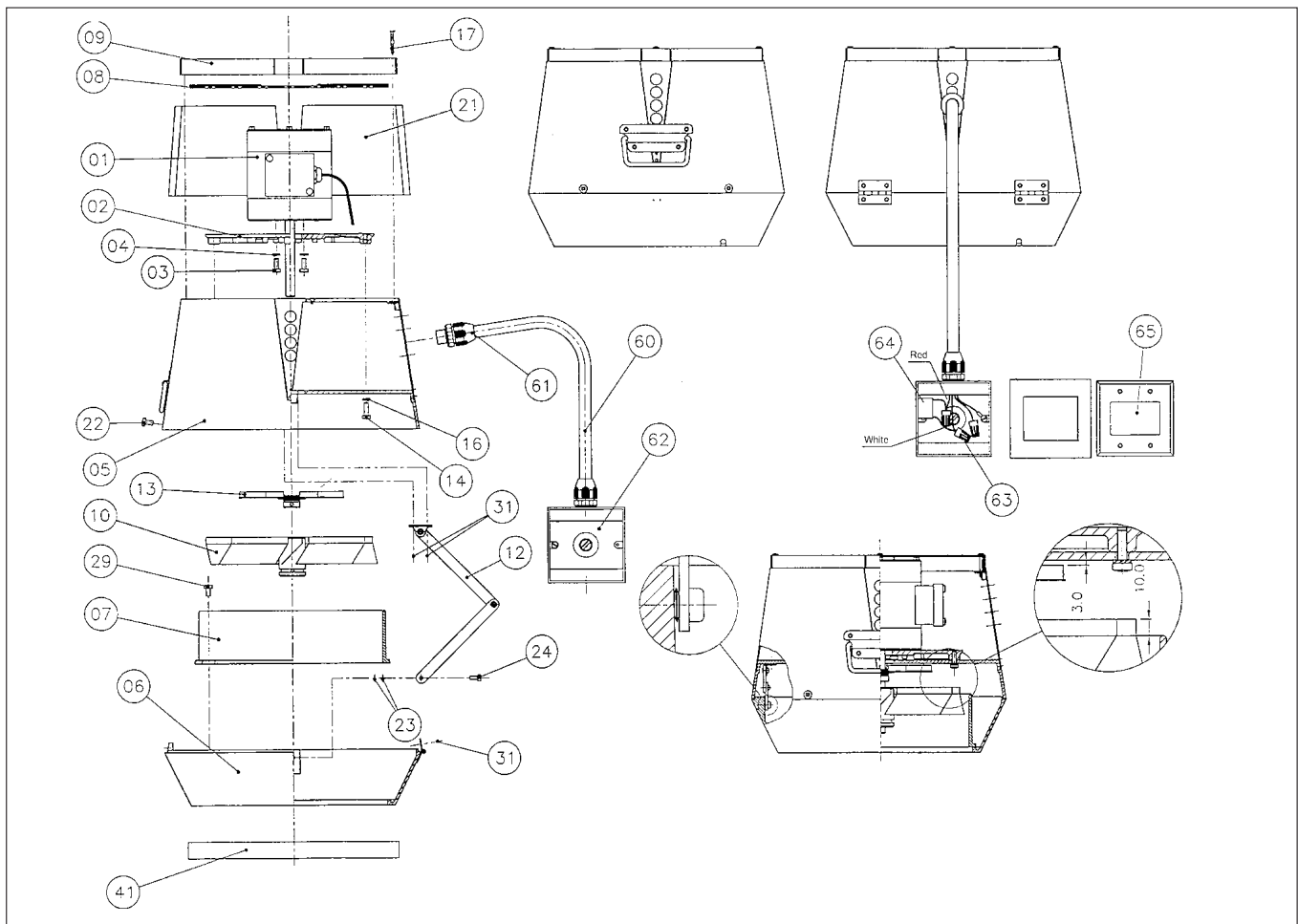

01	Motor	17	Screw – SS (4)
02	Motor mounting plate	21	Motor housing insulation
03	Screw – SS (2)	22	Screw – SS (2)
04	Washer – SS (2)	23	Washer – SS
05	Housing (top)	24	Screw – SS
06	Housing (base)	29	Screw – SS
07	Insert	31	Rivet
08	Bird screen	41	Fiber Mat
09	Top plate	60	3/8" conduit
10	Axial vane	61	3/8" connector
12	Locking hinge (2)	62	Junction box with blank cover
13	Cooling vane	63	Wire nuts
14	Screw – SS	64	Capacitor (1 x 120 V fans only)
16	Washer – SS	65	Wiring diagram (mounted on

6.7 Troubleshooting

Problem	Probable cause	What to do
The fan is not operating.	No power to the fan.	Check the power supply wires in the junction box by the fan. Check the circuit breaker. Check that the fan is actually turned ON.
The fan is not running at full speed and/or is humming.	The capacitor is improperly connected or not connected at all (single-phase fans only).	Check the connections inside the junction box. The capacitor must be installed according to wiring diagram.
The fan is vibrating shaft vigorously.	The motor shaft is damaged. Foreign matter or grease buildup on vane	Turn the power OFF immediately. Open the fan and check if the motor shaft is straight. If not, contact ENERVEX tel. 800.255.2923. Turn off the power and remove the foreign article/clean the fan.
The fan is noisy.	The transportation device has been removed. Foreign matter is stuck in the fan. A ball bearing is damaged.	Remove the transportation device. Turn off the power and remove the foreign article. Turn off the power. Wait for the motor to stop revolving. Spin the wheel and listen for any grinding noise from the motor. If necessary, replace bearing.
The fan suddenly stops.	The motor is overheating.	Check the flue gas temperature below the fan. The temperature should not exceed 400°F during continuous operation. Call ENERVEX tel. 800.255.2923.

Distributor in USA & Canada



ENERVEX Inc.
1685 Bluegrass Lake Parkway
Alpharetta, GA 30004

P: 770.587.3238
F: 770.587.4731
T: 800.255.2923
info@energex.com
www.energex.com