

PDS 1

Proven Draft Switch

USA

CAN

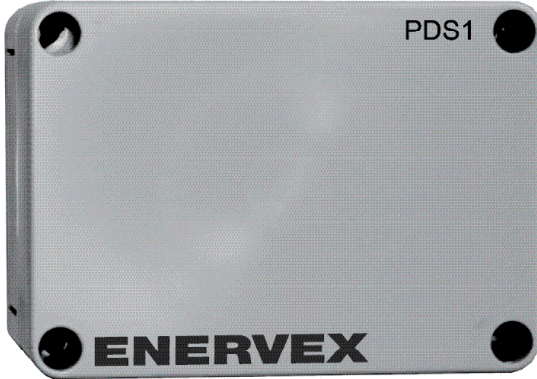

-  **Product Information Chapter 1 + 2**
-  **Mechanical Installation Chapter 3**
-  **Electrical Installation Chapter 4**
-  **Start Up and Configuration Chapter 5**

Volko Supply - Enervex Fan Source
www.enervexfansource.com
800 685 8263

Job Name: _____

Installer: _____

Installation Date: _____

READ AND SAVE THESE INSTRUCTIONS!

ENERVEX Inc.
1685 Bluegrass Lakes Pkwy.
Alpharetta, GA 30004

P: 770.587.3238
F: 770.587.4731
T: 800.255.2923
info@enervex.com
www.enervex.com



1. Product Information2

2. Specifications2

3. Mechanical Installation3

4. Electrical Installation4

5. Startup and Configuration4

i 1. Product Information

1.1 Function

- Use** The PDS 1, Proven Draft Switch, is a fixed position differential pressure switch that is used in conjunction with ENERVEX’s Mechanical Draft Systems for insufficient draft protection. If an unsafe draft condition occurs, whether this is caused by mechanical or electrical failure, the switch will shut down the heating appliance. It is typically used with gas or oil fired appliances where it can be interlocked with the gas supply valve or the safety or control circuit of the appliance.
- Construction** The enclosure, the switch housing and the internal switch are made of polycarbonate. The diaphragm is made of NBR (silicone), while the switching contact is made in fine silver.
- Listings** The switch is UL recognized product

1.2 Components

- Standard packing list** The PDS shipment contains:
- 1 PDS 1 Differential Pressure Switch
 - Duct Kit consisting of stack probe with mounting flange and 6 ft silicone tubing
- If other components are shipped, they will appear as separate items on the shipping packing list.

1.3 Warranty

Complete warranty conditions are available from ENERVEX, Inc.

i 2. Specifications

2.1 Dimensions & Capacities

PDS 1		
Maximum Load	V	1x120 VAC
Amperage	A	3
Range of Operation	inWC/Pa	.05 to .50/13 to 135
Temperature Limits	°F/°C	-40 to +190/ -40 to +88
Max. Pressure	PSI/mbar	3 / 207
Wiring Connections		1/4" Solderless Quick Connect Terminals
Pressure Connections		Two plastic tubes, outside diameter of 1/4" (6.0mm)
Weight	oz. / kg	9.6 / 0.275

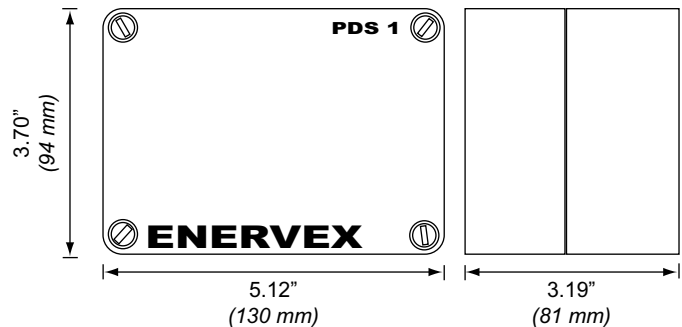



Mechanical Installation

3.1 Installation of Proven Draft Switch (PDS 1)

The PDS 1 is for indoor installation only. The PDS 1 must be installed in a vertical position with the pressure connection pointing down. Secure the switch by using the mounting holes as shown on the figure. After installation connect the tubing from the probe onto the port marked accessible through the small of the plastic enclosure. Connect tubing to the NEGATIVE (-) port on the PDS.

Factory wiring comes with three wires that are already crimped onto the PDS. The purpose of these wires is to provide a point in which you can extend the length of the wire by using wire nuts and additional wire (not provided).

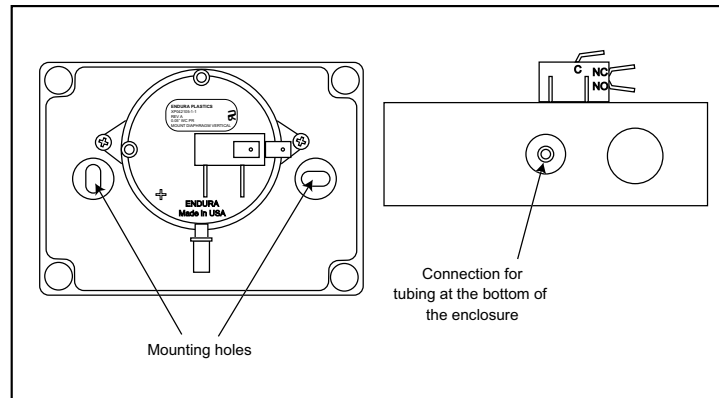

3.2 Installation of Stack Probe for PDS 1

A stack probe is used with ENERVEX Proven Draft Switches (PDS). The PDS 1 monitors the pressure inside the stack and signals the control to shut down the appliance if insufficient draft exists inside the stack. The probe must be installed between the appliance and the exhaust fan.

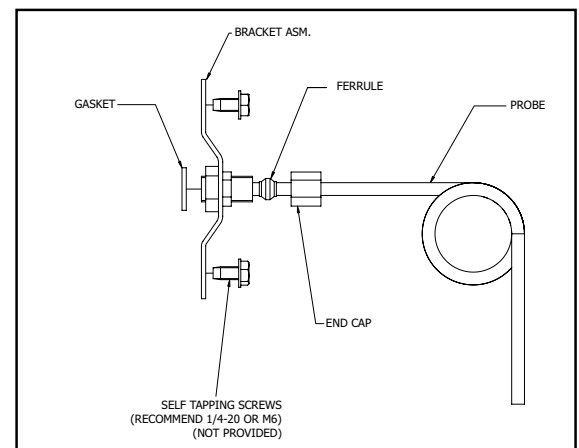

For all installations, the stack probe must be placed so the flow through the stack is perpendicular to the tip of the probe. Locate the probe at least the distance "A" away from any elbows or tees in the stack. The distance "A" is defined as at least three (3) vent diameters; $A \geq 3 * V$ (see figure below). To prevent condensation from entering the probe or PDS when installed on a horizontal stack, the probe must be installed above the centerline of the stack. For fireplace installations, the stack probe should be installed as close to the exhaust fan as possible.

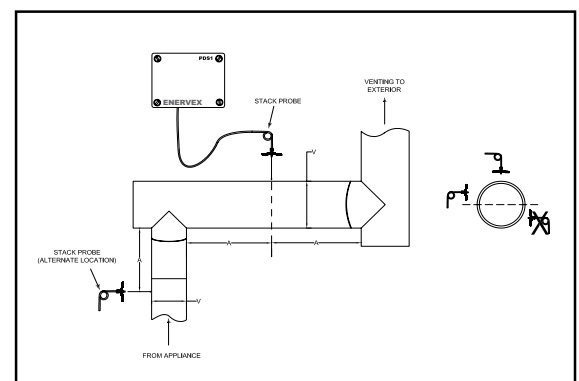

For the PDS to function properly, the probe must be placed in a location that can produce at least 0.05 inWC in the stack. In order to produce an accurate pressure reading, the tip of the probe must be mounted flush with the inside of the stack wall (it should never extend more than 1/16" beyond the wall). For a double walled stack, the tip should be flush with the inner most wall.

To mount the probe, drill a clearance hole through the stack wall(s). Insert the probe and attach the bracket to the stack using (2) customer provided self-tapping machine screws. Tighten the end cap to compress the ferrule and permanently install the stack probe. Attach the supplied silicon tubing at the other end of the probe.

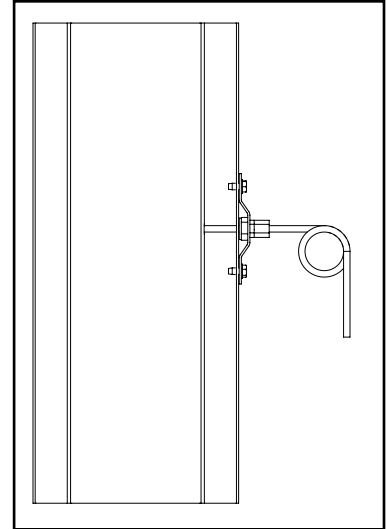

4. Electrical Installation

4.1 Wiring the PDS 1

The PDS 1 must be wired in a Normally Open (NO) position when used with a mechanical draft system.

Make sure to observe the electrical rating of the switch as shown on page 2.

Please refer to the wiring diagram enclosed with the mechanical draft system.



Start Up and Configuration

5.1 The Pressure Setting

The pressure switch has a fixed pressure setting of .05" +/- .03" W.C.

If the switch will not stay closed while the appliance is operating properly, you may need to increase the fan speed or move the probe closer to the vent termination.

However, always make sure the draft at the appliance outlet stays within the manufacturer's specified range. Under-drafting and over-drafting can cause damage to the appliance.

5.2 Commissioning

Start the heating appliance(s) and the mechanical draft system and make sure the PDS 1 stays closed.

Turn off the mechanical draft system. After less than 60 seconds all appliances should be shut down by the switch.

Volko Supply - Enervex Fan Source
www.enervexfansource.com
800 685 8263